

GESTRA Steam Systems

GESTRA Information C 1.2

Utilization of the sensible heat of condensate

Examples of effective steam plant design and appropriate equipment

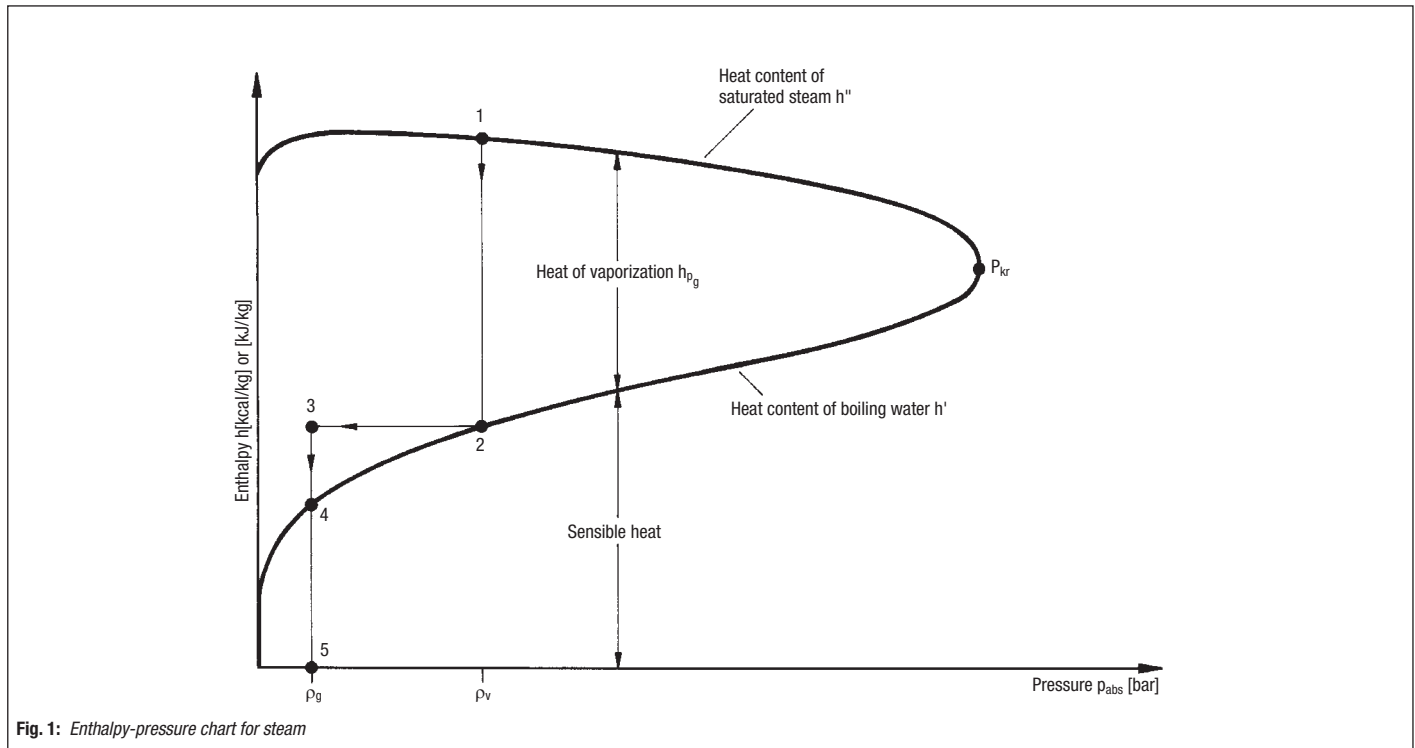

Fig. 1: Enthalpy-pressure chart for steam

Since enormous costs can be saved by utilizing the sensible heat of the condensate everybody using steam should deal with the problem:

How can the sensible heat of the condensate be used in my steam plant?

Steam plant design differs widely, so does plant operation, and the costs required for alterations should be kept as low as possible.

In the following we shall therefore show various possibilities of utilizing the sensible heat of the condensate, one or the other of which can be realized in almost any plant.

Without detailed knowledge of the existing plant it is not possible to say which of the possibilities mentioned could best be applied to a particular plant. The subject can therefore only be treated in general.

What does the expression "utilization of the sensible heat of condensate" convey?

To start with a few fundamentals:

- To heat a product in a heat exchanger to a certain temperature saturated steam should be used.
- The temperature of the saturated steam has to be higher than the final temperature of the product.
- Steam pressure and steam temperature are directly interrelated, i.e. the temperature in the heat exchanger depends on the steam pressure.

- The total heat content of the steam is composed of the heat content of the liquid (sensible heat) and the heat of vaporization (latent heat).

- Normally a heat exchanger is designed to transmit only the latent heat to the product, while the condensate being formed has to be discharged immediately. This is the only way of reaching the maximum capacity and efficiency of the heat exchanger. The heat contained in the condensate (the sensible heat) is, however, discharged with the condensate.

- The condensate and its sensible heat are lost if the condensate is simply discharged into the open and not utilized. If the condensate is collected in an open tank and re-used as boiler feed water, part of the heat of the condensate is lost, i.e. by the flash steam which forms downstream of the steam trap and is discharged to atmosphere. We shall deal with this phenomenon in detail later.

Utilization of the sensible heat of the condensate means exploiting the heat discharged with the condensate from the heat exchanger as far as possible.

To discharge the condensate from the heat exchanger a steam trap is used which acts at the same time as a throttling device. The pressure drop between the heat exchanger and atmosphere or the condensate system therefore occurs in the trap.

If condensate is reduced from a higher to a lower pressure, flash steam is formed. This phenomenon can easily be explained with the enthalpy (h) – pressure (p) chart shown in Fig. 1.

Figures 1 to 5 on the h-p chart signify the following:

- Point 1: Admission of steam into heat exchanger.
- Point 2: Condensate at boiling temperature or with slight undercooling at outlet of heat exchanger or upstream of steam trap.
- Distance 1 – 2: Transmission of vaporization heat in the heat exchanger at constant pressure and temperature.
- Point 3: State downstream of steam trap.
- Distance 2 – 3: Throttling – at constant enthalpy – of pressure (p_v) upstream of steam trap to pressure (p_g) downstream of steam trap or from the temperature upstream of steam trap to boiling temperature.
- Point 4: Condensate at boiling temperature downstream of steam trap.
- Distance 3 – 4: Heat released by throttling process leading to the formation of flash steam.
- Distance 4 – 5: Remaining (sensible) heat in condensate.

The amount of flash steam formed can be calculated as follows:

$$m_D = m \cdot \frac{(h'_2 - h'_4)}{r_{pg}} \quad [\text{kg/h}]$$

m = Amount of condensate [kg/h]

h'_2 = Sensible heat before flashing [kcal/kg or kJ/kg]

h'_4 = Sensible heat after flashing [kcal/kg or kJ/kg]

r_{pg} = Heat of vaporization in the presence of back pressure [kcal/kg or kJ/kg]

Instead of calculating the amount of flash steam it can be read on the chart of **Fig. 2** showing the amount of flash steam (in kg) per kg of condensate as a function of the pressures upstream of the steam trap (in the heat exchanger) and downstream, e.g. as indicated in the chart:

Gauge pressure upstream of steam trap 5 bar.

Gauge pressure downstream of steam trap 0 bar.

Flash steam (revaporization) 0.11 kg/kg, i.e. 11 %.

As we have seen, the amount of flash steam depends on the differential pressure (pressure upstream minus pressure downstream of steam trap) and on the amount of condensate. This fact also explains why a large steam cloud must form downstream of a properly working steam trap.

If the condensate is discharged into an open tank, the flash steam becomes visible when it leaves the tank. In this case the cloud is even bigger as several steam traps discharge into one tank.

At low pressures the specific volume of steam is high. It is impossible to distinguish live steam from flash steam, so that even experts sometimes mistake flash steam for live steam and form the opinion that the steam traps are leaking, although they are functioning correctly.

Fig. 3 serves as an example of the enormous volume of flash steam formed downstream of a steam trap: 100 kg/h of condensate (from steam at a pressure of 8 bar g) from 24 m³/h of flash steam, while the water volume remaining is only 0.086 m³/h.

This illustrates that steam trap monitoring at the outlet of a trap is of no avail and any monitoring equipment should only be installed upstream of steam traps.

However, monitoring is not normally necessary if good-quality steam traps guaranteeing perfect operation are used. From our large trap range, we can offer you reliable traps for any application suiting your particular requirements. Please consult us.

It will be clear by now that the heat contained in the condensate, i.e. the sensible heat available upstream of the steam trap, is divided downstream into flash steam and heat remaining in the condensate.

As the remaining condensate and consequently its heat content are almost always re-used, "utilization of the sensible heat of condensate" can only mean the utilization of flash steam.

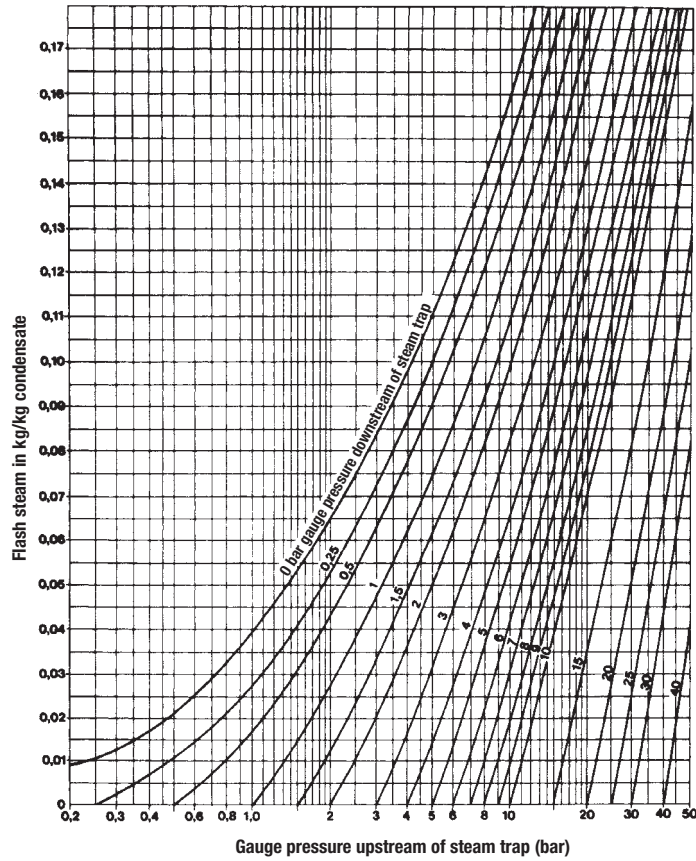

Fig. 2 Amount of flash steam, revaporization during flashing of boiling condensate

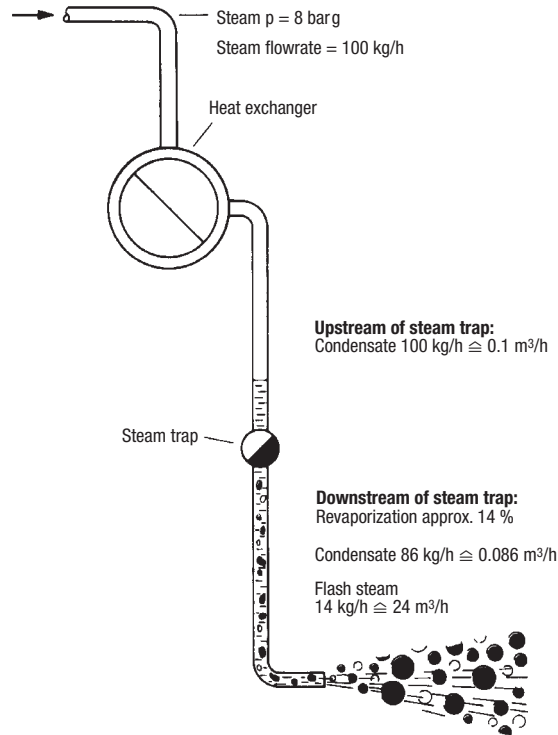

Fig. 3 Increase in volume by formation of flash steam downstream of steam trap

How can the flash steam heat be utilized?

1. By banking-up of condensate
2. By a flash-steam recovery system
3. By connecting a heat exchanger to the condensate main
4. By the connection of a preheater in series.

Which of these possibilities can best be applied depends on the type of the plant.

Concerning 1: Utilization of sensible heat by banking-up of condensate

At first question to be asked is: Can the formation of flash steam not be avoided altogether? The answer is easy: yes, it is possible, if ...

In the following we shall explain why it is not always possible.

To avoid the formation of flash steam downstream of a steam trap, the condensate has to be held back, i.e. it will bank-up in the heat exchanger which becomes partially

filled with water. This means that part of the sensible heat of the condensate is transferred to the product to be heated, the condensate cools down. The condensate temperature has to be cooled down until it reaches or drops below the boiling temperature relative to the pressure at the outlet of the trap. This implies that the cooling line has to be sufficiently long, i.e. the heat exchanger is more or less filled with water. With the usual heat exchangers this is rarely possible, as the banking-up reduces the heating capacity and consequently the efficiency of the heat exchanger and may also lead to waterhammer.

With tracing systems, however, the above method can often be applied by using appropriate steam traps. These are either traps which are adjusted once to a desired undercooling in accordance with the prevailing operating conditions, or traps which, independently of the operating conditions, discharge the condensate e.g. into the open at approx. 85 °C.

Sometimes condensate is also held up in heat exchangers controlled by the condensate temperature. In this case banking-up is required to maintain a given product temperature constant. This type of control is, however, rather sluggish and tends to over module. This type of heating should only be adopted for heat exchangers with vertical heating surfaces and near continuous operation.

Fig. 4 gives such an example with a fuel preheater. On the left (Fig. 4a) a heat exchanger is shown equipped with a thermostatic self-acting temperature controller which controls the condensate flowrate as a function of the product temperature. The steam trap prevents loss of live steam if – when the product is cold – the temperature controller is completely open. On the left (Fig. 4b) a steam trap with an auxiliary thermostat fulfils both functions.

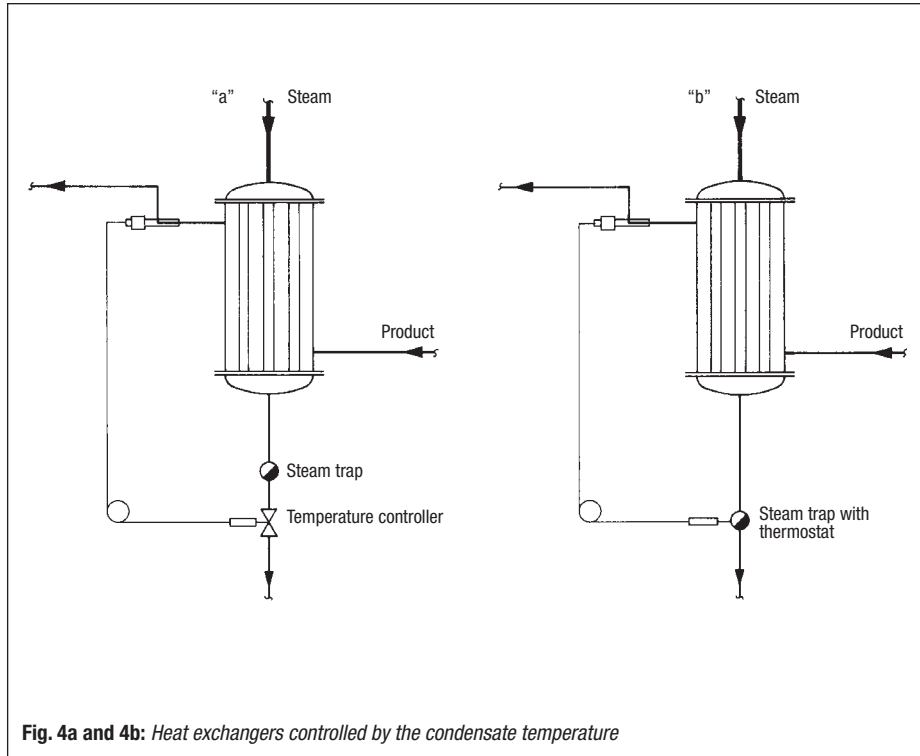

Fig. 4a and 4b: Heat exchangers controlled by the condensate temperature

Concerning 2: Utilization of sensible heat in a flash-steam recovery system

If steam at various pressure ratings is required in a plant this is the best method. If this is not the case, the plant should be re-examined to find out whether one or more of the heat exchangers could not be heated with steam at a lower pressure. This is more often possible than you would think. The only reason for heating all heat exchangers with steam at the same pressure is quite often the simple fact that this pressure is available.

It goes without saying that feed-water deaerators in the boiler house are also low-pressure steam consumers. In most cases they are heated with live steam at a gauge pressure between 0.2 and 0.5 bar. During the heating periods the flash steam can be used for space heating for which low-pressure steam is suitable.

Fig. 5 shows a schematic layout of various heat exchangers heated with steam at different pressures. Instead of the heat exchanger for each pressure rating as shown, several heat exchangers could of course be connected. In this system, which is called an open-condensate system, all flash steam is lost.

The system can be improved so that flash steam will no longer escape. For this purpose the open system is converted into a closed one and flash vessels are installed between the heat exchanger groups. (Flash vessels are pressure vessels where flash steam is separated from condensate).

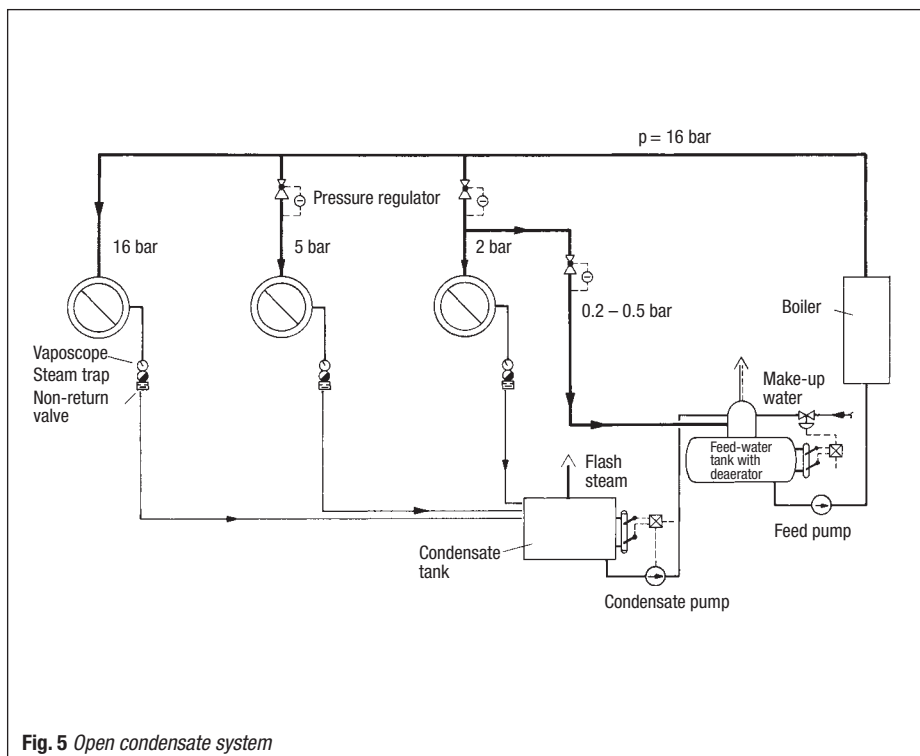

Fig. 5 Open condensate system

Fig. 6 gives an example of a closed system with three flash vessels. The “16 bar” heat exchanger discharges the condensate to the “5 bar” flash vessel. The flash steam from this vessel is fed into the “5 bar” heat exchanger. If the steam supply from the flash vessel is not sufficient, live steam is used for make-up and is controlled by the pressure regulator. The pressure regulator is also used to keep the pressure in the heat exchanger and flash vessel constant. The condensate from the “5 bar” flash vessel is discharged via a float trap into the “2 bar” flash vessel. The condensate from the “2 bar” heat exchanger is also discharged into this vessel. The flash steam from the “2 bar” flash vessel is fed into the “2 bar” heat exchanger. Here again a pressure regulator is provided for adding live steam and, if required, for keeping the pressure constant. The condensate from the “2 bar” heat exchanger and the flash vessel is discharged into the “0.2 – 0.5 bar” flash vessel. The flash steam formed in this vessel is used for feed-water deaerating. The remaining condensate is discharged into the feed-water tank via a level-control system.

As incondensable gases, such as air, would considerably impair the heat transfer an air vent should be provided on the 5 and 2 bar flash vessel. Otherwise the air would be conveyed with the steam into the next heat exchanger.

If an existing plant is modified, e.g. conversion from open to closed condensate system, the steam traps should be examined to establish whether their capacity will be sufficient.

The higher back pressure in a closed system reduces the differential pressure across the trap and hence its capacity.

It is of course not always necessary to use three flash vessels, quite often one or two will suffice. **Figs. 7** and **8** show such systems.

If, as per **Fig. 8**, the flash steam formed in a plant can be completely used in a single heat exchanger, the thermosiphon principle can be applied, the only requirement is a difference in height between heat exchanger and flash vessel.

In accordance with the gas laws the flash steam will flow into the “2 bar” heat exchanger. The condensate having a higher specific gravity will fall back into the flash vessel. The condensate has to enter the vessel below the water level to avoid interference with the rising steam. Efficient deaeration has to be provided to ensure thermosiphon circulation.

This principle cannot be applied unless the heat exchanger operates at constant pressure. A control from the steam side is not possible.

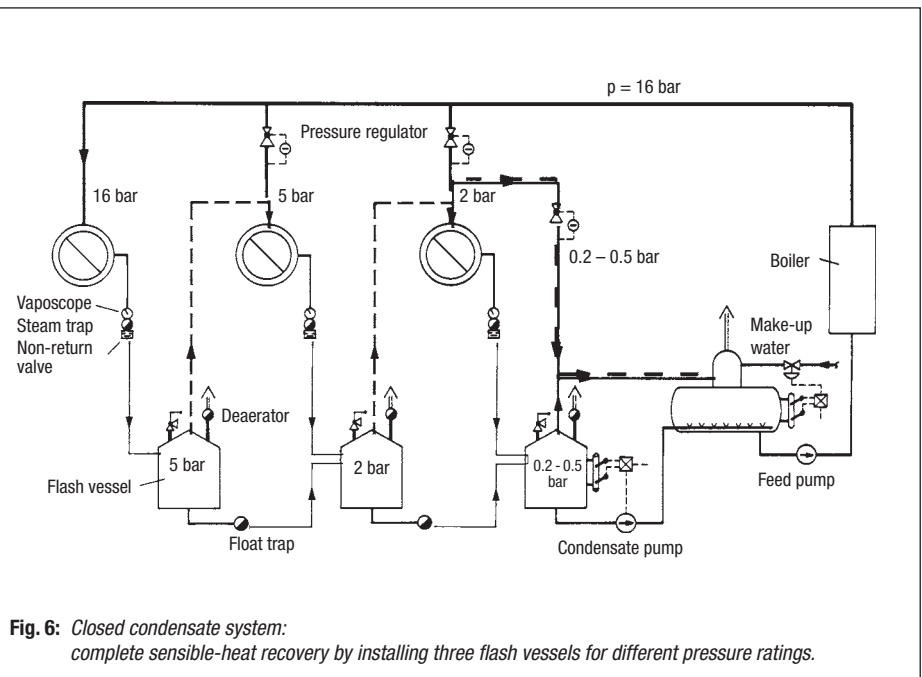

Fig. 6: Closed condensate system: complete sensible-heat recovery by installing three flash vessels for different pressure ratings.

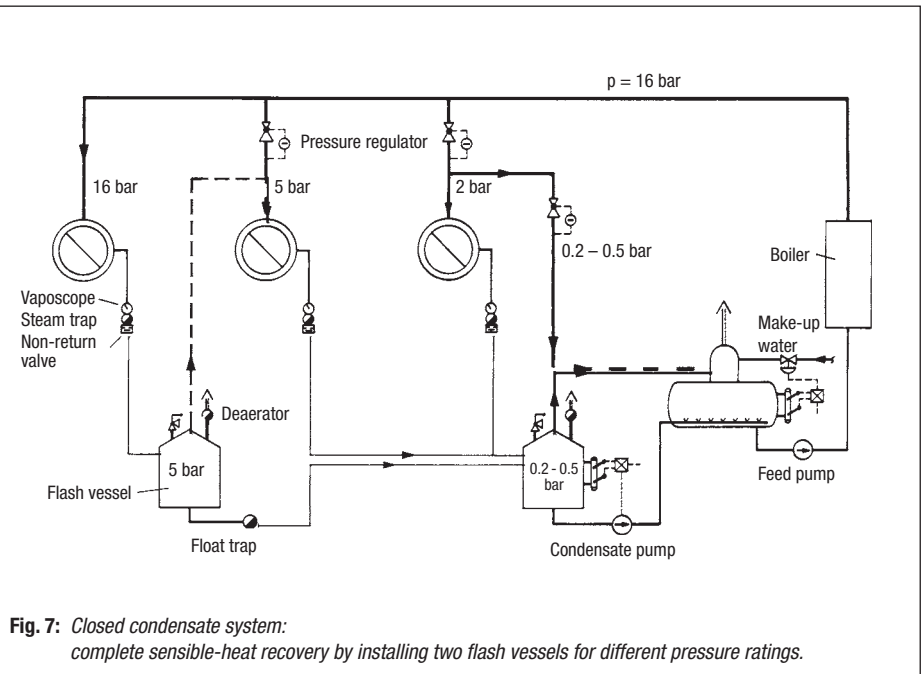

Fig. 7: Closed condensate system: complete sensible-heat recovery by installing two flash vessels for different pressure ratings.

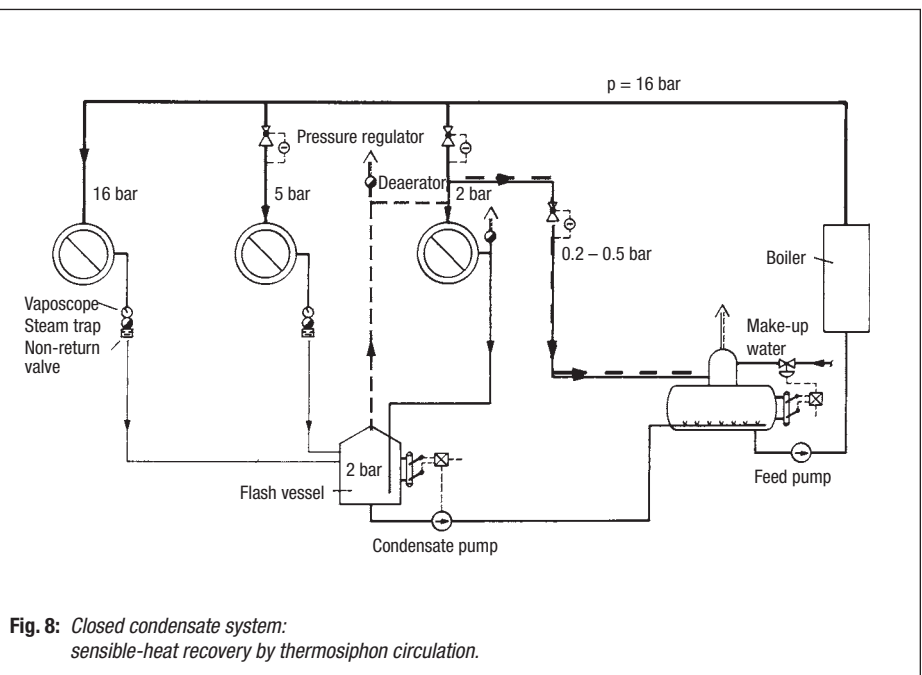
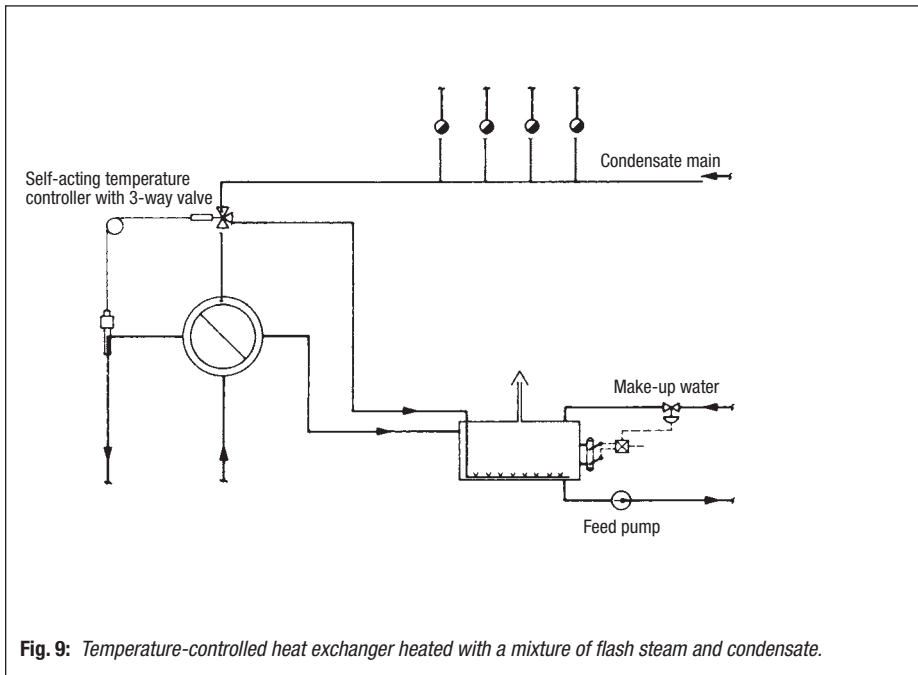

Fig. 8: Closed condensate system: sensible-heat recovery by thermosiphon circulation.

———— Flash steam
 - - - - - Flash and live steam



Concerning 3:
Utilization of sensible heat by connecting a heat exchanger to the condensate main

Fig. 9 shows a schematic layout. The optimum product temperature is maintained with the aid of a temperature controller and a three-way valve. The valve is used to prevent building-up of too much back pressure in the condensate main. For this system to work the amount of waste heat available from the plant has to be higher than the heat required by the heat exchanger.

The flash steam/condensate mixture not required for heating is discharged, below the water level, into the condensate tank. It is used for heating the make-up water.

To avoid waterhammer in the condensate tank the condensate must be discharged below the water level. A sparge pipe should be used with the total area of holes equalling the cross-sectional area of the pipe. The end of the sparge pipe must be blanked off. A small hole should be drilled in the pipe above the water level inside the tank which, on shut-down of the plant, will prevent condensate from being drawn back into the pipeline.

With this system the absolute maximum utilization of flash steam is obtained.

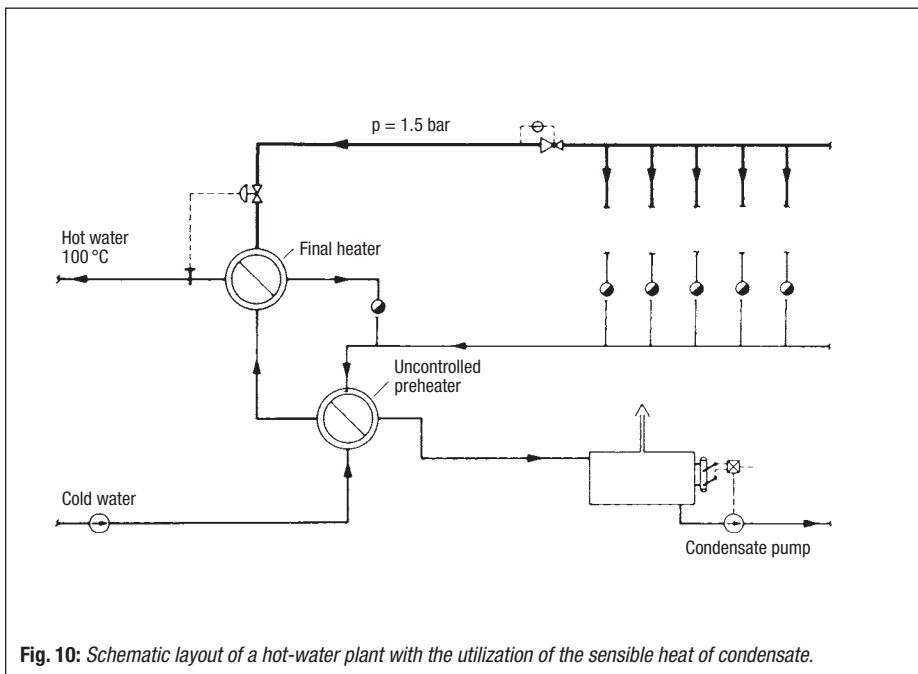

Concerning 4:
Utilization of sensible heat with a preheater in series

If direct utilization of flash steam in a heat exchanger is not possible, a preheater can be connected in series with an existing heat exchanger for the following purpose:

A heat exchanger is required to heat a product from an initial to a desired final temperature. This heating process demands a certain amount of steam. If, however, waste heat is used to preheat the product, a smaller quantity of steam is required for reaching the final product temperature.

The preheating can be effected either by feeding the uncontrolled flash steam to the preheater (if possible, by thermosiphon circulation, see **Fig. 8**), or, in the case of smaller plants, in a preheater fed directly with the condensate/flash steam mixture (**Fig. 10**).

The final heater is required to heat the product – in our example water – to the desired final temperature.

It is of course possible to use several preheaters at different points in the plant, e.g. if the plant is rather big or spread over a wide area.

For large heating units direct utilization of the flash steam and of part of the sensible heat of the condensate is recommended. For this purpose, again a preheater is used which forms part of the heating unit. The preheater can either be installed at the side or below the heating unit.

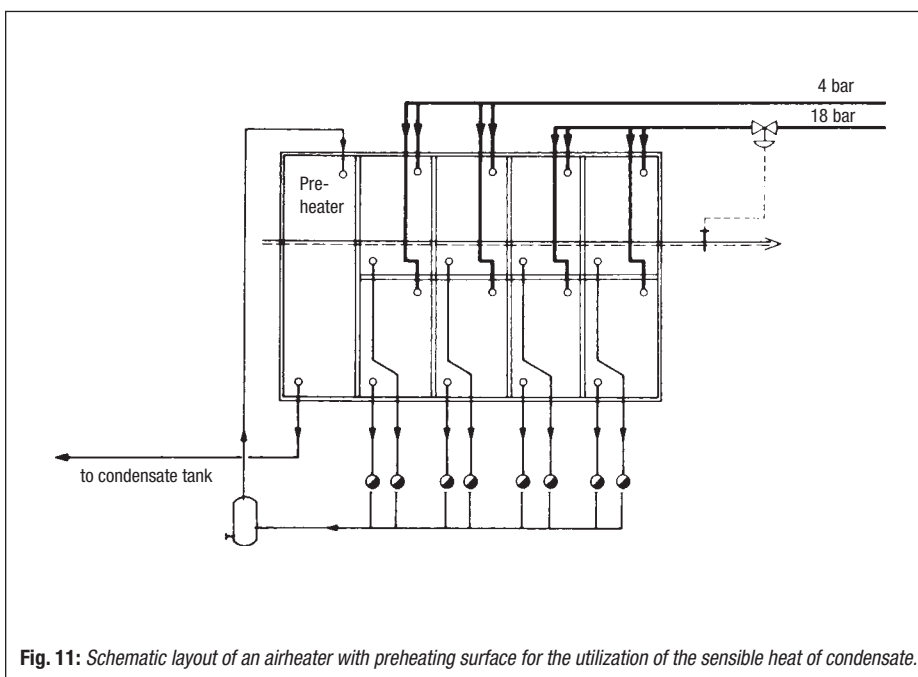

Fig. 11 shows a schematic layout of an air heater provided with a preheater on the inlet. The condensate/flash steam mixture from the various sections passes through the preheater. The heat of vaporization and part of the sensible heat of the condensate are transferred to the cold air. The condensate finally discharged into the condensate tank is relatively cold. The condensate line downstream of the air heater is free from flash steam.

In the example as per **Fig. 12** the preheater is installed **below** the heat exchanger. The hot condensate flows from the heat exchanger by gravity to the preheater and transfers sensible heat to the product. The undercooled condensate is discharged by a float trap via a pipe bend whose highest point is above the preheater. An equalizing pipe is installed between the highest point of the discharge pipe and the heat exchanger, so that the condensate level upstream and downstream of the preheater is equal. By this means the preheater remains flooded and, apart from the slight pressure increase owing to the static head, the preheater and heat exchanger are at the same pressure.

If condensate is formed the level upstream of the preheater rises and causes the cold condensate in the preheater to flow over into the discharge line. The heat exchanger should be provided with an air vent. This design with the preheating surface below the heat exchanger offers advantages when compared with the one as per **Fig. 11** (preheating surface at the side of heat exchanger): The preheater is only fed with water; the inlet temperature is higher; the pipeline diameters can be smaller; cavitation, erosion and waterhammer, phenomena often produced by water/steam mixtures, are avoided.

The size of the preheating surfaces is calculated in accordance with the amount of waste heat available and the desired outlet temperature of the condensate.

We have now treated the subject "Utilization of the sensible heat of condensate" in detail. If you want to improve the thermal balance of your plant by avoiding unnecessary heat losses you should examine which of the possibilities mentioned could best be realized in your plant. We should be pleased to discuss the matter with you and prepare a detailed plan tailored to your specific requirements. We are of course also in a position to supply the necessary equipment.

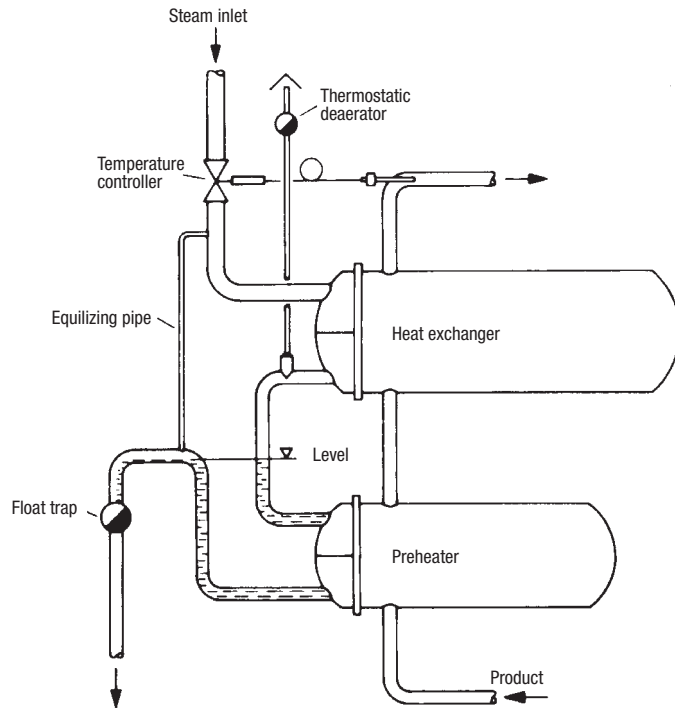

Fig. 12: Utilization of the sensible heat of condensate in a preheater.

GESTRA AG

P. O. Box 10 54 60, D-28054 Bremen
 Münchener Str. 77, D-28215 Bremen
 Telephone +49 (0) 421 35 03 - 0, Fax +49 (0) 421 35 03-393
 E-Mail gestra.ag@flowserve.com, Internet www.gestra.de



GESTRA