



Industrial Controller

KS 90-1

EN
English

Original Installation Instructions
819132-00

Contents

Page

Important Notes

Usage for the intended purpose	4
Function	4
Safety note	5

Directives and Standards

VdTÜV Bulletin "Wasserüberwachung 100" (= Water Monitoring 100)	5
LV (Low Voltage) Directive and EMC (Electromagnetic Compatibility)	5
ATEX (Atmosphère Explosible)	5
Note on the Declaration of Conformity / Declaration by the Manufacturer CE	5

Technical data

KS 90-1	6 – 7
Scope of supply	7

In control cabinet: Mounting the industrial controller

Dimensions KS 90-1	8
Installation	9

In control cabinet: Wiring the industrial controller

Wiring diagram	10
Key	10
Wiring the output contacts OUT1...OUT4	11
Wiring the safety circuit OUT4	11
Wiring the conductivity transmitter INP1	11
Wiring the control input DI1, control OFF	11
Wiring the control input DI2, external setpoint selection	11

In the plant: Wiring the conductivity transmitter

Wiring the conductivity transmitter	12
Tools	12

Contents - continued -

Page

Operating the industrial controller

Parameter setting	13
Key	13
Parameter setting	14
Key to codes on seven-segment display and default settings	14

Commissioning procedure

Parameter setting	15
External setpoint selection, parameter setting	16 - 17

Operation

Manual operation.....	17
Control OFF.....	18

Troubleshooting

Display, diagnosis and remedy.....	18 - 19
------------------------------------	---------

Further Notes

Protection against high frequency interference	19
Decommissioning / replacing the equipment	19
Disposal.....	19

Important Notes

Usage for the intended purpose

The industrial controller KS 90-1 is used in conjunction with the conductivity transmitter LRGT 1.-.. as continuous blowdown controller and conductivity limiter (to control the concentration of total dissolved solids = TDS), e. g. in steam boilers and (pressurised) hot-water plants. The industrial controller signals when the preset max. and min. limit is reached and controls the continuous blowdown valve BAE.

The industrial controller KS 90-1 is designed for use with the conductivity transmitter types LRGT 16-1, LRGT 16-2 and LRGT 17-1.

Function

The industrial controller KS 90-1 processes the conductivity-dependent current signal of the conductivity transmitter LRGT 1.-.. or externally specified setpoints.

In the industrial controller KS 90-1 the input signal is standardized according to the conductivity measurement range and the switchpoints for MIN / MAX limits within this range are variably adjusted.

During normal operation the actual value and the setpoint for continuous blowdown control are indicated on the seven-segment LED display.

When the MIN or MAX limit is reached, the MIN or MAX output contact is switched over and LED 3 or 4 is illuminated.

The industrial controller KS 90-1 works also as PI-type continuous blowdown controller. Once the adjusted setpoint is reached, the controller output contacts switch over according to the preset control parameters and the continuous blowdown valve is activated or deactivated. At the same time LED 2 (valve opens) or LED 1 (valves closes) lights up.

To avoid losing boiler water during stand-by operation you can energize the control input DI1 in order to de-activate the continuous blowdown control system and to close the continuous blowdown valve.

If faults occur in the electrical connection of the conductivity transmitter, a MIN alarm is triggered and the continuous blowdown valve closes.

Important Notes - continued -

Safety note

The equipment fulfils a safety function and must only be installed, wired and commissioned by qualified and competent staff.

Retrofitting and maintenance work must only be performed by qualified staff who - through adequate training - have achieved a recognised level of competence.



Danger

The terminal strips of the equipment are live during operation.

This presents the danger of electric shock!

Always **cut off power supply** to the equipment before mounting, removing or connecting the terminal strips!



Attention

The name plate specifies the technical features of the equipment. Note that any piece of equipment without its specific name plate must neither be commissioned nor operated.

Directives and Standards

VdTÜV Bulletin “Water Monitoring 100”

The industrial controller KS 90-1 in conjunction with the conductivity transmitter LRGT 1.-.. is type approved according to VdTÜV Bulletin “Water Monitoring 100”.

The VdTÜV Bulletin “Water Monitoring 100” states the requirements made on water monitoring equipment.

LV (Low Voltage) Directive and EMC (Electromagnetic Compatibility)

The equipment meets the requirements of the Low Voltage Directive 2006/95/EC and the EMC Directive 2004/108/EC.

ATEX (Atmosphère Explosible)

According to the European Directive 94/9/EC the equipment must **not** be used in explosion risk areas.

Note on the Declaration of Conformity / Declaration by the Manufacturer CC

For details on the conformity of our equipment according to the European Directives see our Declaration of Conformity or our Declaration of Manufacturer.

The current Declaration of Conformity / Declaration of Manufacturer are available in the Internet under www.gestra.de/documents or can be requested from us.

Technical data

KS 90-1

Supply voltage

90 – 250 VAC, 48 - 62 Hz

Power consumption

8.0 VA

Inputs

1 actual value input INP1, 4-20 mA, for conductivity transmitter LRGT 1.-., screened, with 2 poles
1 supplementary input INP2, 4-20 mA, for external setpoint selection
2 control inputs DI1, DI2, configured as switch for connecting volt-free contacts, switched voltage: 5 V, current 100 µA.

Outputs:

Relay outputs

Volt-free change-over contact

Max. contact rating: 500 VA, 250 V, 2 A at 48...62 Hz,

Min. contact rating: 6 V, 1 mA DC.

Switching cycle, electric: For I=1 A/2 A: > 800,000 / 500,000 (at AC 250 V (resistive load))

Provide inductive loads with RC combinations according to manufacturer's specification to ensure interference suppression.

Indicators and adjustors

1 display with bar chart and plain text

4 amber LEDs with relay outputs OUT1...OUT4,

4 pushbuttons for parameter setting and selection manual/automatic

Enclosure

Makrolon 9415, flame retardant

Flammability class: UL 94 V0, self-extinguishing.

Plug-in module, inserted from the front

Electrical connections

Screw terminals for conductor cross-sections from 0.5 to 2.5 mm²

Safety & protection

Overvoltage category II

Contamination class 2

Operating voltage range 300 V

Protection II

Protection

Front: IP 65 to EN 60529

Enclosure: IP 20

Connections: IP 00

Weight

approx. 0.27 kg

Ambient temperature

during operation 0 ... 60 °C

Transport temperature

-40 ... +70 °C (<100 hours), defrosting time of the de-energized equipment before it can be put into operation: 24 hours.

Technical Data - continued -

KS 90-1 - continued -

Storage temperature

-40 ... +70 °C, defrosting time of the de-energized equipment before it can be put into operation:
24 hours.

Relative humidity

75 % yearly average, no condensation

Approvals:

TÜV certificate

VdTÜV Bulletin "Wasserüberwachung 100" (= Water Monitoring 100):
Requirements made on water level monitoring equipment

Type approval no. TÜV · WÜL · XX-003
(see name plate)

Scope of supply

KS 90-1

- 1 Industrial controller KS 90-1
- 2 Fixing clamps
- 1 Installation & operating manual
- 1 Short installation manual

In control cabinet: Mounting the industrial controller

Dimensions KS 90-1

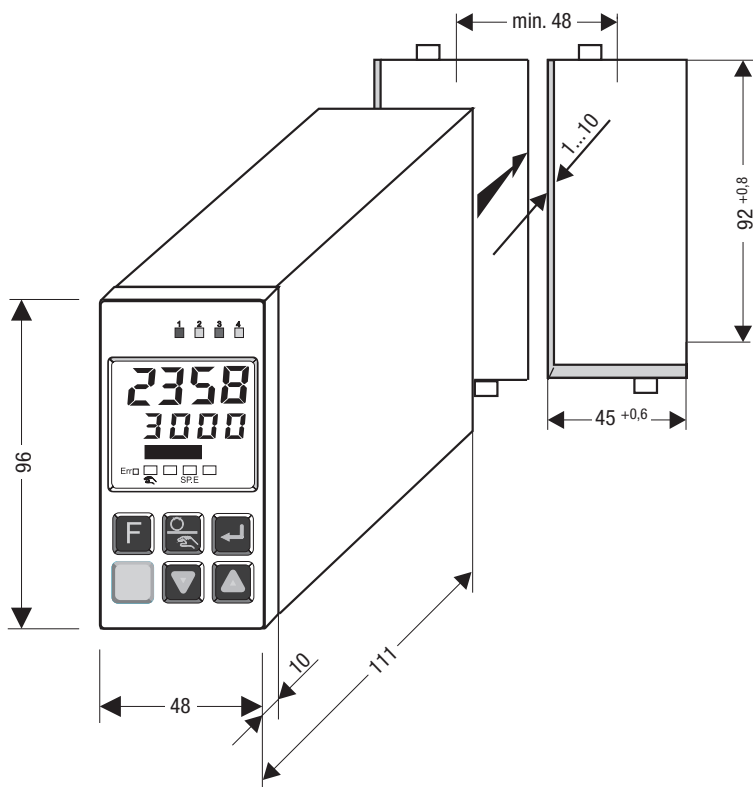

Fig. 1

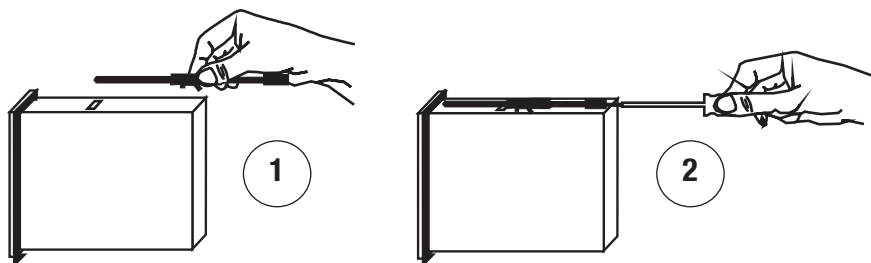

Fig. 2

Installation

Installation in control cabinet Fig. 2.

1. Provide panel cut-out, dimensions: $45^{+0.6} \times 92^{+0.8}$.
2. Mount the industrial controller KS 90-1 using the fixing clamps supplied with the equipment. **Fig. 2**



Attention

- Make sure that the mounted industrial controller KS 90-1 is sufficiently ventilated so that the max. admissible ambient temperature is not exceeded during operation.



Note

If a gasket is inserted between the front and the control panel the panel front has protection class IP 65. **Fig. 2**

In control cabinet: Wiring the industrial controller

Wiring diagram

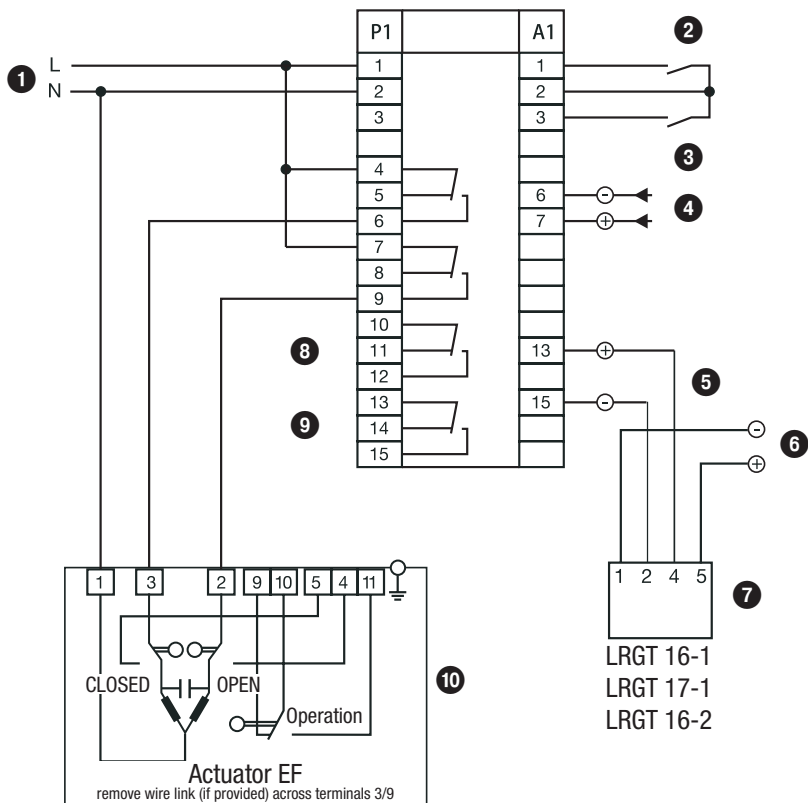

Fig. 3

Key

- ① Connection of supply voltage **90 .. 260 V AC**
- ② Control input DI1, stand by, control OFF
- ③ Control input DI2, external setpoint selection
- ④ INP2, connection for external setpoint
- ⑤ INP1, connection for conductivity transmitter
- ⑥ Connection of supply voltage **24 V DC** for conductivity transmitter
- ⑦ Conductivity transmitter
- ⑧ MIN output contact OUT3
- ⑨ MAX output contact OUT4
- ⑩ Actuator EF

In control cabinet: Wiring the industrial controller - continued -

Wiring the output contacts OUT1...OUT4

Wire the terminal strip P (terminals 1-15) according to the desired switching functions. Provide an external slow-blow fuse 2.5 A for the output contacts. When switching off inductive loads, voltage spikes are produced that may impair the operation of control and measuring systems. Connected inductive loads must be provided with suppressors such as RC combinations as specified by the manufacturer.

Wiring the safety circuit OUT4

If the equipment is used as conductivity limiter connect the safety circuit for the heating to the terminals 13/15 (OUT4). Provide an external slow-blow fuse 1.2 A for the output contact.



Note

The equipment does not interlock automatically in the event of an alarm (MAX limit exceeded). If an interlock function is required for the installation it must be provided in the follow-up circuitry (safety circuit). The circuitry must meet the requirements of the EN 50156.

Wiring the conductivity transmitter INP1

To connect the equipment use screened multi-core control cable with a min. conductor size 0.5 mm², e. g. LiYCY 2 x 0.5 mm², max. length: 250 m.

Wire terminal strip in accordance with the wiring diagram. **Fig. 3**

Connect the screen **only once** to the conductivity transmitter.

Make sure that connecting cables leading to the equipment are segregated and run separately from power cables.

Wiring the control input DI1, control OFF

To avoid losing boiler water during stand-by operation you can energize the control input DI1 in order to de-activate the continuous blowdown control system and to close the continuous blowdown valve.

The control input is energized by a volt-free make contact connected to the terminals 1 and 2 of terminal strip A1.

Wiring the control input DI2, external setpoint selection

The external setpoint selection can be activated by energizing the control input DI2.

The control input is energized by a volt-free make contact connected to the terminals 2 and 3 of terminal strip A1.

Please connect the external setpoint 0/4 -20 mA to terminals 6 and 7+ of terminal strip A1.

In the plant: Wiring the conductivity transmitter

Wiring the conductivity transmitter

The industrial controller KS 90-1 is designed for use with the conductivity transmitter types LRGT 16-1, LRGT 16-2 or LRGT 17-1.

To connect the equipment use screened multi-core control cable with a min. conductor size 0.5 mm², e. g. LiYCY 2 x 0.5 mm², max. length: 250 m.

Check the **conductivity transmitter** for correct wiring of the screen.



Attention

- Please follow the instructions given in the installation & operating manual for the LRGT 1.-.
- Make sure that connecting cables leading to the equipment are segregated and run separately from power cables.
- Do not use unused terminals as support point terminals.

Tools

- Screwdriver for slotted screws, size 3.5 x 100 mm, completely insulated according to VDE 0680-1.

Operating the industrial controller

Setting parameters

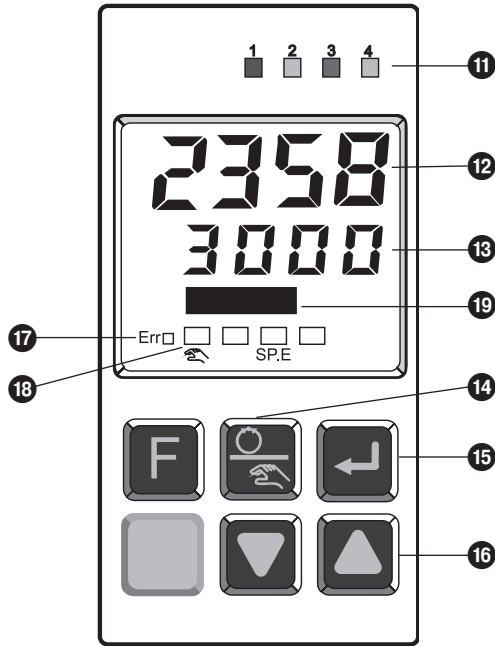

Fig. 4

Key

- 11 State of the output contacts Out 1...4 (LED 3 = MIN, LED 4 = MAX)
- 12 Display of actual value ($\mu\text{S}/\text{cm}$)
- 13 Display of setpoint ($\mu\text{S}/\text{cm}$)
- 14 Manual/automatic key
- 15 Enter key
- 16 Arrow keys
- 17 LED Error
- 18 LED manual operation / external setpoint (S.P.E)
- 19 Bar graph display (deviation)



Note

The upper display line always shows the actual value. When the equipment is in parameterization, configuration and calibration mode the lower display line switches cyclically between parameter name and parameter value.

Setting parameters

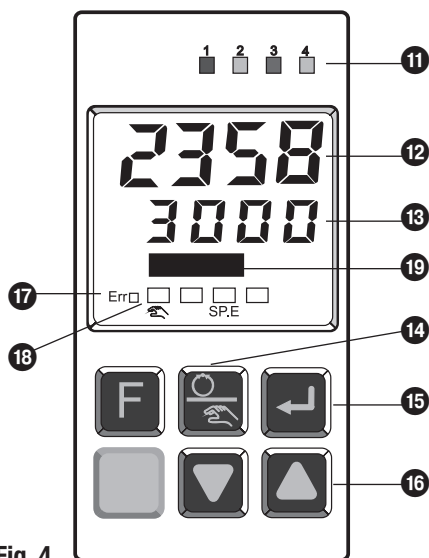

- 11 State of the output contacts Out 1...4 (LED 3 = MIN, LED 4 = MAX)
- 12 Display of actual value ($\mu\text{S}/\text{cm}$)
- 13 Display of setpoint ($\mu\text{S}/\text{cm}$)
- 14 Manual/automatic key
- 15 Enter key
- 16 Arrow keys
- 17 LED Error
- 18 LED Manual operation
- 19 Bar graph display (deviation)

Fig. 4

Key to codes on seven-segment display and basic settings

Code	Description	Factory-set default value
OuL.1	Lower scaling point 1	
OuH.1	Upper scaling point 1	
t.F1	Filter time constant 1	5 sec.
Pb1	Proportional band 1	500 %
ti1	Integral action time 1	500 sec.
SH	Neutral zone (dead band)	100 μS
L.1	MIN limit	
H.2	MAX limit	
Appears with external setpoint selection		
InL.2	Lower current input value	0
OuL.2	Lower scaling point 2	100 μS
InH.2	Upper current input value	20
OuH.2	Upper scaling point 2	
t.F2	Filter time constant 2	5 sec.
Appears if malfunctions occur		
Fail	Error	
FbF	Sensor damaged	
Break	Interruption	

Commissioning procedure

Setting parameters

Start		
Activity	Display	Function
Switch on supply voltage.	Display is being tested.	After applying the supply voltage the equipment starts in the operator control level. The equipment will be in the operating mode in which it was active before the power was cut. If the controller was in manual operating mode when the supply voltage was switched off it will start again in manual mode with the last control output when it is switched on again.

Setpoint setting		
Press and hold down the Enter key 15 until the setpoint appears in the second line. Then use the arrow keys to set the desired value. The setting can also be changed during operation.		
Setting parameters		
Activity	Function	
In the second line the display switches between parameter name and value. Use the arrow keys to set the values.		
Press and hold down the Enter key 15 until the parameter OuL.1 appears. Then set the desired value.	Set the lower scaling point to 1 (µS) (LRGT 1.-1) or 100 (µS) (LRGT 16-2).	
Press and hold down the Enter key until the parameter OuH.1 appears. Then set the desired value.	Set the upper scaling point to, e. g. 200 (LRGT 1.-1) or 3000 (LRGT 16-2).	
Press and hold down the Enter key until the parameter t.F1 appears. Then set the desired value.	Adjust the damping factor for the input signal. Note that steam bubbles can affect the readings, causing the measured value to oscillate. The oscillations of the measured value can be dampened by increasing the filter time constant t.F1 setting.	
Press and hold down the Enter key until the parameter Pb1 appears. Then set the desired value.	Set the proportional band of the controller. The narrower the proportional band, the larger the corrective action in relation to a given deviation will be.	
Press and hold down the Enter key until the parameter ti1 appears. Then set the desired value.	Set the integral action time. The longer the integral time, the smoother and more gradual the corrective action will be.	
Press and hold down the Enter key until the parameter SH appears. Then set the desired value.	Set the neutral zone (dead band). The larger this value, the higher the admissible deviation from the setpoint will be before corrective action takes place.	
Press and hold down the Enter key until the parameter L.1 appears. Then set the desired value.	Set the MIN limit.	
Press and hold down the Enter key until the parameter H.2 appears.	Set the MAX limit. If the equipment is used as conductivity (TDS) limiter, set the predefined max. electrical conductivity.	
Changes will be saved automatically. After setting the parameters press and hold down the Enter key until the setpoint is indicated in the lower display line or wait for approx. 30 seconds. After this time the controller returns to normal operating mode and the actual value and the setpoint will be indicated.		

External setpoint selection, parameter setting

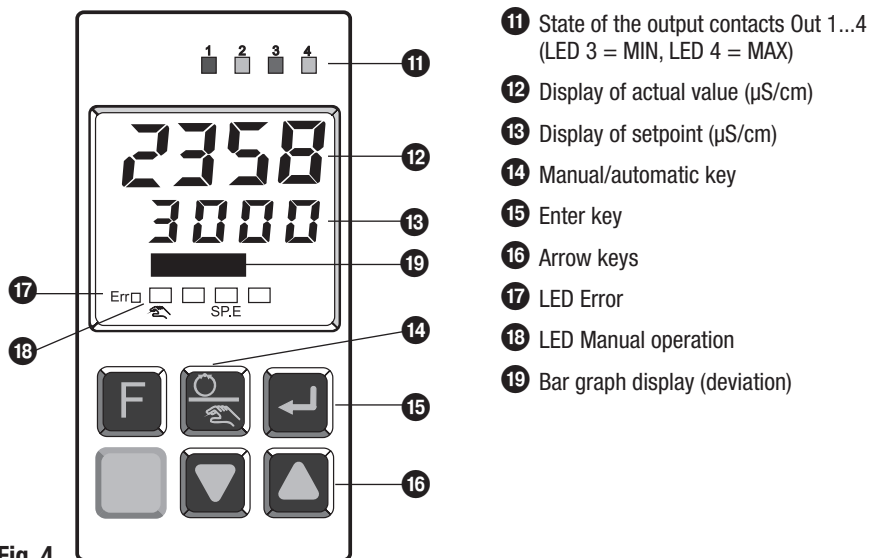

Fig. 4

- 11 State of the output contacts Out 1...4 (LED 3 = MIN, LED 4 = MAX)
- 12 Display of actual value ($\mu\text{S}/\text{cm}$)
- 13 Display of setpoint ($\mu\text{S}/\text{cm}$)
- 14 Manual/automatic key
- 15 Enter key
- 16 Arrow keys
- 17 LED Error
- 18 LED Manual operation
- 19 Bar graph display (deviation)

External setpoint selection

The external setpoint selection can be activated by energizing the control input DI2. The control input is energized by a volt-free make contact connected to the terminals 2 and 3 of terminal strip A1.

Activity	Display	Function
Hold down the Enter key for at least 5 seconds.	PArA	The controller is now in parameterization mode.
Press the Enter key once.		This confirms your input.
Use the arrow keys until you reach the external setpoint InP.2 . Press the enter key to confirm the input.	InP.2	You can now set the desired parameters.

Commissioning - continued -

External setpoint selection, parameter setting - continued -

Setting parameters	
Activity	Function
In the second line the display switches between parameter name and value. Use the arrow keys to set the values.	
Press and hold down the Enter key until the parameter InL.2 appears. Then set the desired value.	Set the lower current input value (0 or 4 mA).
Press and hold down the Enter key until the parameter OuL.2 appears. Then set the desired value.	Set the lower scaling point to 1 (µS) (LRGT 1.-1) or 100 (µS) (LRGT 16-2).
Press and hold down the Enter key until the parameter InH.2 appears. Then set the desired value.	Set the upper current input value (20 mA).
Press and hold down the Enter key until the parameter OuH.2 appears. Then set the desired value.	Set the upper scaling point to, e. g. 200 (LRGT 1.-1) or 3000 (LRGT 16-2).
Press and hold down the Enter key until the parameter t.F1 appears. Then set the desired value.	Adjust the damping factor for the input signal. Note that steam bubbles can affect the readings, causing the measured value to oscillate. The oscillations of the measured value can be dampened by increasing the filter time constant t.F1 setting.
Changes will be saved automatically. After setting the parameters press and hold down the Enter key until the setpoint is indicated in the lower display line or wait for approx. 30 seconds. After this time the controller returns to normal operating mode and the actual value and the setpoint will be indicated.	

Operation

Manual operation

Activity	Display	Function
Press the Manual/Automatic key	Y LED "Manual operation" is illuminated.	The controller is now in manual operation mode.
Press the arrow keys until the desired valve position is attained.	LEDs 1 and 2 are illuminated.	The connected continuous blowdown valve is opened or closed.
Press the Manual/Auto key or the Enter key.		The controller returns to normal operating mode.

Operation - continued -

Control OFF

To avoid losing boiler water during stand-by operation you can energize the control input DI1 in order to de-activate the continuous blowdown control system and to close the continuous blowdown valve.

The control input is energized by a volt-free make contact connected to the terminals 1 and 2 of terminal strip A1.

Activity	Function
Energize the control input DI1 via a volt-free make contact.	The continuous blowdown control is switched off and for 5 minutes a signal is sent to close the continuous blowdown valve.
Open the make contact for the control input DI1.	The continuous blowdown control is switched on again and the continuous blowdown valve is motored into the position required by the control system.

Troubleshooting

Indication, diagnosis and remedy



Attention

Before carrying out the fault diagnosis please check:

Supply voltage:

Is the equipment supplied with the voltage specified on the name plate?

Wiring:

Is the wiring in accordance with the wiring diagram?

Alarms and faults are entered in the error list and indicated by the LED Error in the display. To view the error list press the Enter key twice.

Fault indication		
LED Err/Status	Description	What to do
flashing (status 2)	Alarm condition, malfunction	- Determine the type of malfunction in the error list. - After the fault is corrected, the system goes to status 2.
illuminated (status 1)	Fault was corrected, alarm not yet acknowledged	- Press one of the arrow buttons to acknowledge the alarm in the error list. - This will delete the alarm entry (status 0).
off (status 0)	no fault, all alarm entries deleted	not visible, only during acknowledgement

Error list			
Name	Description	Cause	Possible remedy
FbF.1	Sensor damaged INP1	- Faulty sensor - Incorrect wiring	- Replace conductivity transmitter. - Check connecting cable.
FbF.2	Sensor damaged INP2	- External setpoint sensor defective - Incorrect wiring	- Replace the external setpoint sensor. - Check the connecting cable.

Troubleshooting - continued -



Attention

In the event of a malfunction (FbF.1) the continuous blowdown valve closes and the output contact OUT3, terminals 10/12 is open.
The output contact OUT 4, terminals 13/15 (conductivity limiter) remains closed.

Further Notes

Action against high frequency interference

Should sporadic failures occur in installations susceptible to faults (e. g. malfunctions due to out-of-phase switching operations) we recommend the following actions in order to suppress interferences:

- Provide inductive loads with RC combinations according to manufacturer's specification to ensure interference suppression.
- Increase the distance to sources of interference.
- Check screens and shields.
- HF interference suppression by means of hinged-shell ferrite rings.
- Make sure that connecting cables leading to the equipment are segregated and run separately from power cables.

Decommissioning / replacing the equipment

- Switch off mains voltage and **cut off power supply** to the equipment.
- Cut off voltage supply and disconnect all electrical connections.
- Remove fixing clamps **Fig. 2** and take the equipment out of the control cabinet.

Disposal

For the disposal of the equipment observe the pertinent legal regulations concerning waste disposal.

If faults occur that are not listed above or cannot be corrected, please contact our service centre or authorized agency in your country.



Agencies all over the world: www.gestra.de

GESTRA AG

Münchener Straße 77

28215 Bremen

Germany

Telefon +49 421 3503-0

Telefax +49 421 3503-393

E-mail info@de.gestra.com

Web www.gestra.de