

UNA 45hi MAX, UNA 46hi MAX, UNA 46Ah MAX

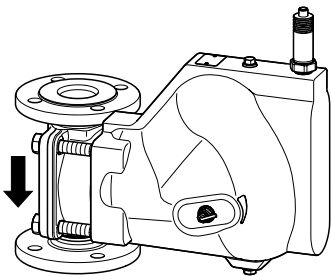

UNA 45v MAX with cover for mounting electrode

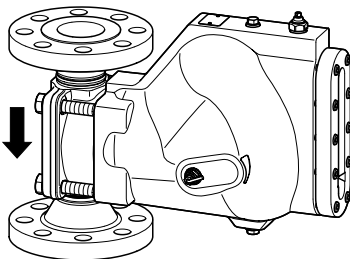

UNA 45v MAX with sightglass cover

Ball Float Steam Trap

UNA 45 MAX, UNA 46 MAX, UNA 46A MAX PN 40/Class 300 DN 40, 50, 65

Description

UNA 45 MAX, UNA 46 MAX and UNA 46A MAX are items of equipment for the steam process designed for the effective removal of condensate from steam.

The ball float opens the orifice as a function of the liquid level. A rising level results in a proportional opening of the equipment. The max. discharge capacity depends on the size of the fully open orifice (O).

As the float rises with the liquid level it pulls the nozzle stem off the pilot valve, allowing a small amount of fluid to flow through the pilot valve.

The fluid compresses the bellows of the control unit and, as a consequence, the discharge orifice is completely uncovered. Equipment with control unit SIMPLEX is particularly suitable for cold condensates and superheated steam.

Equipment with control unit DUPLEX may also be used for air venting the installation. The control unit DUPLEX consists of a float and a temperature dependent air-venting facility. The air venting is controlled by the membrane regulator. Equipment with this type of control unit is particularly suitable for saturated steam systems. Do not expose the membrane regulator capsule of the DUPLEX control unit to superheat conditions above 5 K.

The optional float-lifting lever allows you to lift the float manually. The optional hand-vent valve allows you to air vent the pipe manually.

The equipment must only be used within the allowable pressure and temperature limits and only if the chemical and corrosive influences on the equipment are taken into account.

Function

The control unit opens the orifice as a function of the liquid level. A rising level results in a proportional opening of the equipment. The max. discharge capacity depends on the orifice size when the ball is completely lifted off its seat and the orifice is fully open.

Optional extras

Standard cover with two lateral connections (with sealings plugs) for later attachment of measuring electrode and/or manual float-lifting lever

Float-lifting lever allows the float to be manually lifted (for purging any dirt away from the seat area)

Hand-vent valve allows manual air-venting the pipeline

Horizontal flow direction (hr) from left to right

(when viewed from the body end)

Sightglass cover PN 16/CL 150

Special cover for mounting measuring electrode

NRG 16-19 or NRG 16-27

The different equipment versions allow you to adjust the flow direction of the equipment to the flow pattern of your installation. The flow arrow must correspond to the direction of the fluid flow. The following positions of installation are possible:

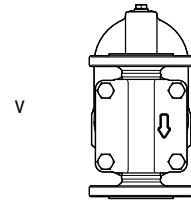

Design "v" for installation in vertical pipework with downward flow

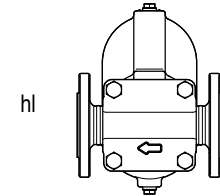

"hl" for horizontal left

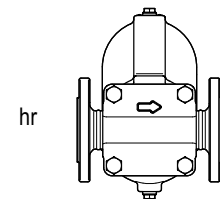

"hr" for horizontal right

End connections

Flange EN 1092-1 B1 PN 40

Flange ASME B 16.5 Class 150 RF, 300 RF

Screwed sockets G: ISO 228/1

Screwed sockets NPT: ASME B 16.11

Socket-weld ends to DIN EN 12760

Socket-weld ends ASME B 16.11 Class 3000

Butt-weld ends via transition pieces to EN 12627, welded joint geometry ISO 9692-1 code number 1.3 (30° chamfer)

Butt-weld ends via transition pieces

ASME B 16.25 ASME B 36.10

Materials

Component part	Type	EN	ASTM
Body	UNA 45 MAX, UNA 46 MAX	1.0460	A105
	UNA 46A MAX	1.4404	A182-F316L
Cover	UNA 45 MAX, sightglass cover Cover for mounting electrodes	5.3103	A395 ¹⁾
	UNA 46 MAX	1.0619	A216-WCB
	UNA 46A MAX	1.4408	A351-CF8M
Body gasket, controller gasket, adapter gasket, gasket for reflexion water level gauge	all	Graphite CrNi	
Membrane regulator capsule	all	Hastelloy / stainless steel	
Other components	all	Stainless steel	

¹⁾ Physical and chemical properties comply with EN grade. ASTM nearest equivalent grade is stated for guidance only.

Explosion view of UNA 45 MAX, UNA 46 MAX, UNA 46A MAX

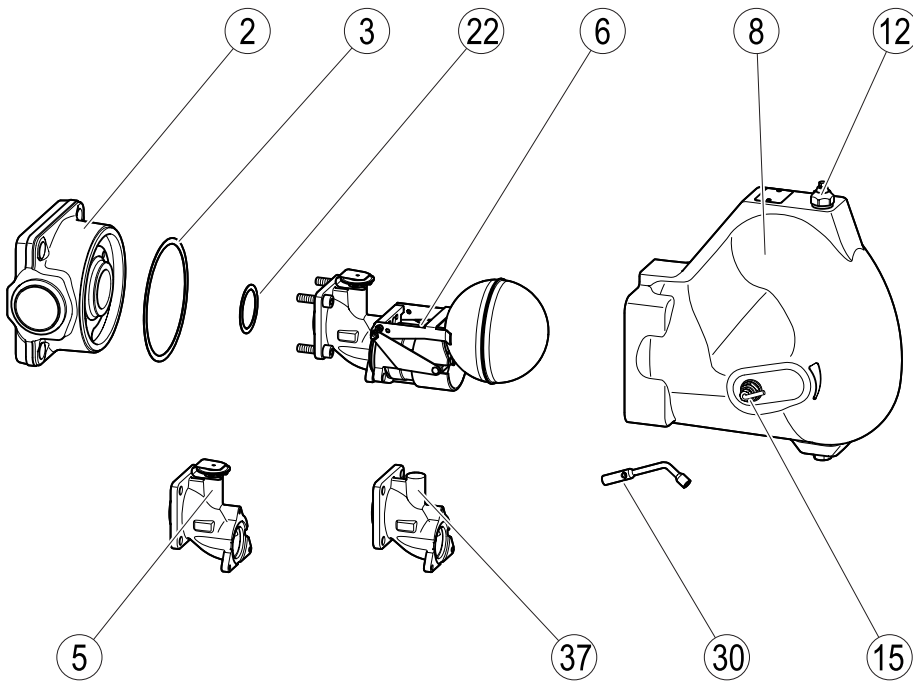

Item no.	Designation
2	Body
3	Body gasket
22	Adapter gasket
6	Control unit (shown here: control unit DUPLEX)
8	Cover (shown here: standard cover)
12	Hand vent valve
15	Float-lifting lever
30	Socket spanner
37	Adapter for SIMPLEX version
5	Adapter for DUPLEX version

Dimensions and weights

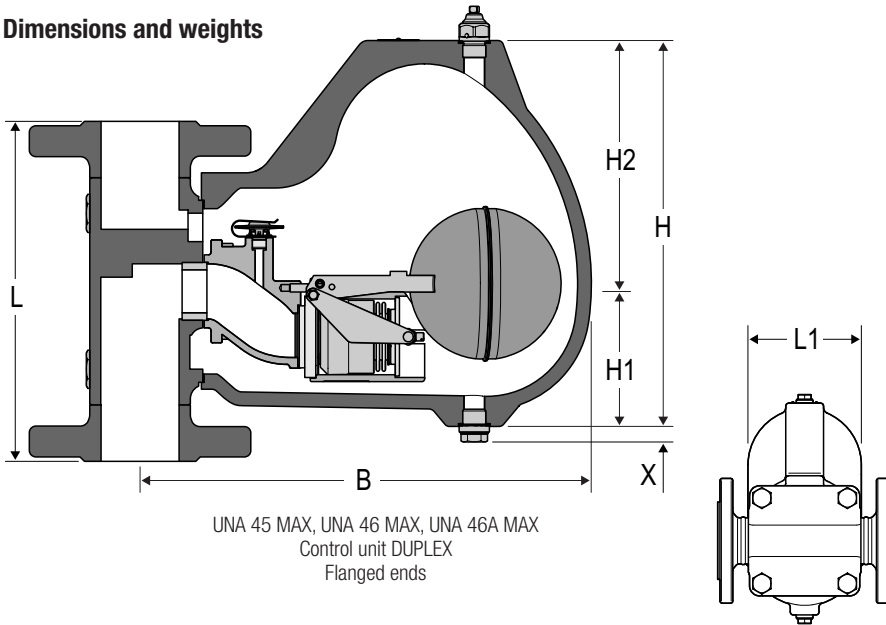

Space required for servicing

To remove the cover a withdrawal space S of 270 mm is required.

If the supplied socket spanner is attached to the equipment an additional clearance of 100 mm is required.

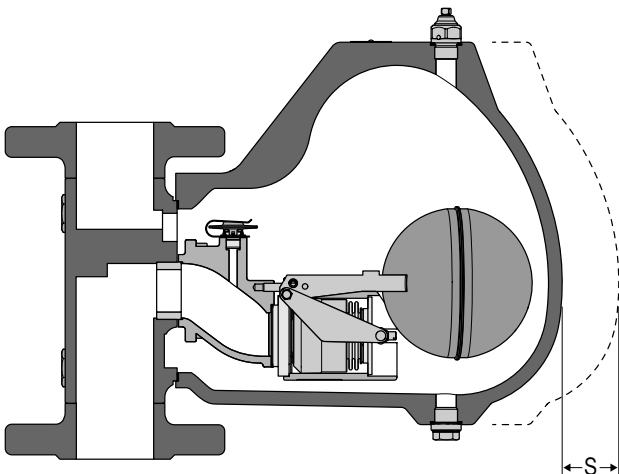

Dimensions and weights

Equipment with flanges EN 1092-1 PN 10–40

Nominal size	Type of cover	DN 40 (1½")	DN 50 (2")	DN 65 (2½")
L [mm (in)]	All	230 (9.1)		290 (11.4)
B [mm (in)]	Standard cover	328 (12.9)		
	Sightglass cover	370 (14.6)		
	Cover for mounting electrodes	343 (13.5)		
H1 [mm (in)]	All	98 (3.9)		
H2 [mm (in)]	All	182 (7.2) ¹⁾		
H [mm (in)]	All	280 (11.0) ¹⁾		
L1 [mm (in)]	All	160 (6.3) ²⁾		
X [mm (in)]	All	13 (0.5)		
Weight [kg]	Standard cover	33.6	35.1	37.4
	Sightglass cover	37.5	39.0	41.3
	Cover for mounting electrodes	35.5	36.9	39.3
Weight [lb]	Standard cover	74.1	77.4	82.5
	Sightglass cover	82.7	86.0	91.0
	Cover for mounting electrodes	78.3	81.3	86.6

¹⁾ If equipped with hand-vent valve add 25 mm (1 in).

²⁾ If equipped with float-lifting lever add 35 mm (1.4 in).

Equipment with flange ASME CL150 and CL300

Nominal size	Type of cover	Class 150			Class 300		
		DN 40 (1½")	DN 50 (2")	DN 65 (2½")	DN 40 (1½")	DN 50 (2")	DN 65 (2½")
L [mm (in)]	All	241 (9.5)	267 (10.5)	292 (11.5)	241 (9.5)	267 (10.5)	292 (11.5)
B [mm (in)]	Standard cover	328 (12.9)					
	Sightglass cover	370 (14.6)			–		
	Cover for mounting electrodes	343 (13.5)					
H1 [mm (in)]	All	98 (3.9)					
H2 [mm (in)]	All	182 (7.2) ¹⁾					
H [mm (in)]	All	280 (11.0) ¹⁾					
L1 [mm (in)]	All	160 (6.3) ²⁾					
X [mm (in)]	All	13 (0.5)					
Weight [kg]	Standard cover	32.6	34.6	38.2	34.8	36.2	39.9
	Sightglass cover	36.5	38.5	42.1	–		
	Cover for mounting electrodes	34.5	36.5	40.1	36.7	38.1	41.7
Weight [lb]	Standard cover	71.9	76.3	84.2	76.7	79.8	88.0
	Sightglass cover	80.5	84.9	92.8	–		
	Cover for mounting electrodes	76.1	80.5	88.4	80.9	84.0	91.9

¹⁾ If equipped with hand-vent valve add 25 mm (1 in).

²⁾ If equipped with float-lifting lever add 35 mm (1.4 in).

Dimensions and weights - continued -

Equipment with socket-weld ends

Nominal size	Type of cover	DN 40 (1½")	DN 50 (2")	DN 65 (2½")
L [mm (in)]	All	165 (6.5)	267 (10.5)	292 (11.5)
B [mm (in)]	Standard cover	328 (12.9)		
	Sightglass cover	370 (14.6)		
	Cover for mounting electrodes	343 (13.5)		
H1 [mm (in)]	All	98 (3.9)		
H2 [mm (in)]	All	182 (7,2) ¹⁾		
H [mm (in)]	All	280 (11,0) ¹⁾		
L1 [mm (in)]	All	160 (6,3) ²⁾		
X [mm (in)]	All	13 (0.5)		
Weight [kg]	Standard cover	29.9	30.9	32.2
	Sightglass cover	33.8	34.8	36.1
	Cover for mounting electrodes	31.7	32.8	34.1
Weight [lb]	Standard cover	65.9	68.1	71.0
	Sightglass cover	74.5	76.7	79.6
	Cover for mounting electrodes	69.9	72.3	75.2

1) If equipped with hand-vent valve add 25 mm (1 in).

2) If equipped with float-lifting lever add 35 mm (1.4 in).

Equipment with screwed socket

Nominal size	Type of cover	DN 40 (1½")	DN 50 (2")
L [mm (in)]	All	165 (6.5)	
B [mm (in)]	Standard cover	328 (12.9)	
	Sightglass cover	370 (14.6)	
	Cover for mounting electrodes	343 (13.5)	
H1 [mm (in)]	All	98 (3.9)	
H2 [mm (in)]	All	182 (7,2) ¹⁾	
H [mm (in)]	All	280 (11,0) ¹⁾	
L1 [mm (in)]	All	160 (6,3) ²⁾	
X [mm (in)]	All	13 (0.5)	
Weight [kg]	Standard cover	30.1	29.6
	Sightglass cover	34.0	33.5
	Cover for mounting electrodes	32.0	31.4
Weight [lb]	Standard cover	66.4	65.3
	Sightglass cover	75.0	73.9
	Cover for mounting electrodes	70.5	69.2

1) If equipped with hand-vent valve add 25 mm (1 in).

2) If equipped with float-lifting lever add 35 mm (1.4 in).

Equipment with butt-weld end via transition pieces

Nominal size	Type of cover	DN 40 (1½")	DN 50 (2")	DN 65 (2½")
L [mm (in)]	All	241 (9.5)	267 (10.5)	292 (11.5)
B [mm (in)]	Standard cover	328 (12.9)		
	Sightglass cover	370 (14.6)		
	Cover for mounting electrodes	343 (13.5)		
H1 [mm (in)]	All	98 (3.9)		
H2 [mm (in)]	All	182 (7,2) ¹⁾		
H [mm (in)]	All	280 (11,0) ¹⁾		
L1 [mm (in)]	All	160 (6,3) ²⁾		
X [mm (in)]	All	13 (0.5)		
Weight [kg]	Standard cover	30.1	30.4	31.3
	Sightglass cover	34.0	34.3	35.2
	Cover for mounting electrodes	32.0	32.3	33.2
Weight [lb]	Standard cover	66.4	67.0	69.0
	Sightglass cover	75.0	75.6	77.6
	Cover for mounting electrodes	70.5	71.2	73.2

1) If equipped with hand-vent valve add 25 mm (1 in).

2) If equipped with float-lifting lever add 35 mm (1.4 in).

Pressure & temperature ratings

The values indicated in the following tables apply to standard equipment.

Note that the type of end connection used may restrict the use of the equipment to below the pressure/temperature limits quoted.

All equipment specific values are indicated on the nameplate.

Limiting conditions for UNA 45 MAX and UNA 46 MAX: Flange PN 40, screwed socket G

Pressure ¹⁾ p	[barg]	40	37.1	33.3	27.6	25.7	13.1 ²⁾
Temperature ¹⁾ T	[°C]	-10/20	100	200	300	350	450 ²⁾
Max. admissible differential pressure ΔPMX	[barg]	4, 8, 13, 22, 32					
	[psi]	58, 116, 188, 320, 465					
Admissible service temperature	Control unit DUPLEX: Saturated steam temperature plus 5 K						
Pressure ¹⁾ p	[psig]	580	538	483	400	373	190 ²⁾
Temperature ¹⁾ T	[°F]	14/68	212	392	572	662	842 ²⁾

1) Resistance limits for body/cover to EN 1092-1

2) Not for UNA 45 MAX

Limiting conditions for UNA 45 MAX and UNA 46 MAX: Flange Class 150

Pressure ¹⁾ p	[barg]	19.6	17.7	13.8	10.2	8.6	5.5 ²⁾
Temperature ¹⁾ T	[°C]	-29/20	100	200	300	345	425 ²⁾
Max. admissible differential pressure ΔPMX	[barg]	4, 8, 13 (19.6 barg with orifice 22, 32)					
	[psi]	58, 116, 188, (284 psi with orifice 22, 32)					
Admissible service temperature	Control unit DUPLEX: Saturated steam temperature plus 5 K						
Pressure ¹⁾ p	[psig]	285	260	200	140	125	80 ²⁾
Temperature ¹⁾ T	[°F]	-20/100	200	400	600	650	800 ²⁾

1) Resistance limits for body/cover to ASME B 16.5

2) Not for UNA 45 MAX

Limiting conditions for UNA 45 MAX and UNA 46 MAX: Flange Class 300, screwed socket NPT, socket-weld end, butt-weld end

Pressure ¹⁾ p	[barg]	51.1	46.6	43.8	39.8	37.8	28.8 ²⁾
Temperature ¹⁾ T	[°C]	-29/20	100	200	300	345	425 ²⁾
Max. admissible differential pressure ΔPMX	[barg]	4, 8, 13, 22, 32					
	[psi]	58, 116, 188, 320, 465					
Admissible service temperature	Control unit DUPLEX: Saturated steam temperature plus 5 K						
Pressure ¹⁾ p	[psig]	740	680	635	570	550	410 ²⁾
Temperature ¹⁾ T	[°F]	-20/100	200	400	600	650	800 ²⁾

1) Resistance limits for body/cover to ASME B 16.5

2) Not for UNA 45 MAX

Limiting conditions for UNA 45 MAX with sightglass cover: Flange PN 16, screwed socket G

Pressure ¹⁾ p	[barg]	16.0	14.8	14.0	13.3	12.3	
Temperature ¹⁾ T	[°C]	-10/20	100	150	200	240	
Max. admissible differential pressure ΔPMX	[barg]	4, 8, 13 (16 barg with orifice 22, 32)					
	[psi]	58, 116, 188, (230 psi with orifice 22, 32)					
Admissible service temperature	Control unit DUPLEX: Saturated steam temperature plus 5 K						
Pressure ¹⁾ p	[psig]	232	215	203	193	178	
Temperature ¹⁾ T	[°F]	14/68	212	302	392	464	

1) Resistance limits for body/cover to EN 1092-1

Operating data

Equipment with sightglass cover:

PN16: max. service temperature 240 °C at a service pressure of 12.3 bar

Class 150: max. service temperature 240 °C at a service pressure of 12.4 bar

If the pH value is above 9.0 and the fluid temperature exceeds 200° C the glass will wear down faster.

Equipment with measuring electrode NRG 16-19 or NRG 16-27, PN 40/Class 300: max. service temperature 238° C at 32 bar service pressure

The max. differential pressure Δ PMX of the equipment depends on the type of orifice (O) used.

Orifice ... MAX	ΔPMX [barg]	Diameter of bore [mm]
4	4	27.5
8	8	19.4
13	13	15.3
22	22	11.7
32	32	9.7

Equipment with control unit DUPLEX: max. service temperature corresponds to the saturation temperature +5K.

Limiting conditions - continued -

**Limiting conditions for UNA 45 MAX with sightglass cover:
Flange Class 150, screwed socket NPT, socket-weld end, butt-weld end**

Pressure ¹⁾ p	[barg]	19.6	17.7	15.8	13.8	12.4	
Temperature ¹⁾ T	[°C]	-29/20	100	150	200	240	
Max. admissible differential pressure ΔPMX	[barg]	4, 8, 13 (19.6 barg with orifice 22, 32)					
	[psi]	58, 116, 188, (284 psi with orifice 22, 32)					
Admissible service temperature		Control unit DUPLEX: Saturated steam temperature plus 5 K					
Pressure ¹⁾ p	[psig]	285	260	230	200	180	
Temperature ¹⁾ T	[°F]	-20/100	200	300	400	465	

1) Resistance limits for body/cover to ASME B 16.5

Limiting conditions for UNA 46A MAX: Flange PN 40, screwed socket G

Pressure ¹⁾ p	[barg]	40.0	37.9	31.8	27.6	25.7	25
Temperature ¹⁾ T	[°C]	-10/20	100	200	300	400 ²⁾	450 ²⁾
Max. admissible differential pressure ΔPMX	[barg]	4, 8, 13, 22, 32					
	[psi]	58, 116, 188, 320, 465					
Admissible service temperature		Control unit DUPLEX: Saturated steam temperature plus 5 K					
Pressure ¹⁾ p	[psig]	580	550	461	400	373	363
Temperature ¹⁾ T	[°F]	14/68	212	392	572	752	842

1) Resistance limits for body/cover to EN 1092-1

2) If the operating temperatures exceed 300 °C intercrystalline corrosion may occur. Do not subject the equipment to operating temperatures higher than 300° C unless intercrystalline corrosion can be ruled out.

Limiting conditions for UNA 46A MAX: Flange Class 150

Pressure ¹⁾ p	[barg]	15.9	13.3	11.2	10.0	6.5	5.5
Temperature ¹⁾ T	[°C]	-29/20	100	200	300	400 ²⁾	425 ²⁾
Max. admissible differential pressure ΔPMX	[barg]	4, 8, 13 (15.9 barg with orifice 22, 32)					
	[psi]	58, 116, 188, (230 psi with orifice 22, 32)					
Admissible service temperature		Control unit DUPLEX: Saturated steam temperature plus 5 K					
Pressure ¹⁾ p	[psig]	230	195	160	140	95	80
Temperature ¹⁾ T	[°F]	-20/100	200	400	600	750	800

1) Resistance limits for body/cover to ASME B 16.5

2) If the operating temperatures exceed 300 °C intercrystalline corrosion may occur. Do not subject the equipment to operating temperatures higher than 300° C unless intercrystalline corrosion can be ruled out.

**Limiting conditions for UNA 46A MAX:
Flange Class 300, screwed socket NPT, socket-weld end, butt-weld end**

Pressure ¹⁾ p	[barg]	41.4	34.8	29.2	26.1	24.3	23.9
Temperature ¹⁾ T	[°C]	-29/20	100	200	300	400 ²⁾	425 ²⁾
Max. admissible differential pressure ΔPMX	[barg]	4, 8, 13, 22, 32					
	[psi]	58, 116, 188, 320, 465					
Admissible service temperature		Control unit DUPLEX: Saturated steam temperature plus 5 K					
Pressure ¹⁾ p	[psig]	600	510	420	370	355	345
Temperature ¹⁾ T	[°F]	-20/100	200	400	600	750	800

1) Resistance limits for body/cover to ASME B 16.5

2) If the operating temperatures exceed 300 °C intercrystalline corrosion may occur. Do not subject the equipment to operating temperatures higher than 300° C unless intercrystalline corrosion can be ruled out.

Operating data

Equipment with sightglass cover:

PN16: max. service temperature 240 °C at a service pressure of 12.3 bar

Class 150: max. service temperature 240 °C at a service pressure of 12.4 bar

If the pH value is above 9.0 and the fluid temperature exceeds 200° C the glass will wear down faster.

Equipment with measuring electrode NRG 16-19 or NRG 16-27, PN 40/Class 300: max. service temperature 238° C at 32 bar service pressure

The max. differential pressure Δ PMX of the equipment depends on the type of orifice (O) used.

Orifice ... MAX	ΔPMX [barg]	Diameter of bore [mm]
4	4	27.5
8	8	19.4
13	13	15.3
22	22	11.7
32	32	9.7

Equipment with control unit DUPLEX: max. service temperature corresponds to the saturation temperature +5K.

Capacity Chart

The chart shows the maximum capacities for hot condensate for the respective orifice.

The capacities are dependent on the differential pressure (working pressure). The differential pressure is the difference between inlet and outlet pressure and depends among other things on the run of the condensate line. If the condensate downstream of the trap is lifted, the differential pressure is reduced by 1 bar for 7 m lift.

The maximum admissible differential pressure is dependent on the cross-sectional area of the orifice and the density of the liquid to be discharged.

The charts show the maximum capacities for hot and cold condensate.

Capacity chart for hot condensate

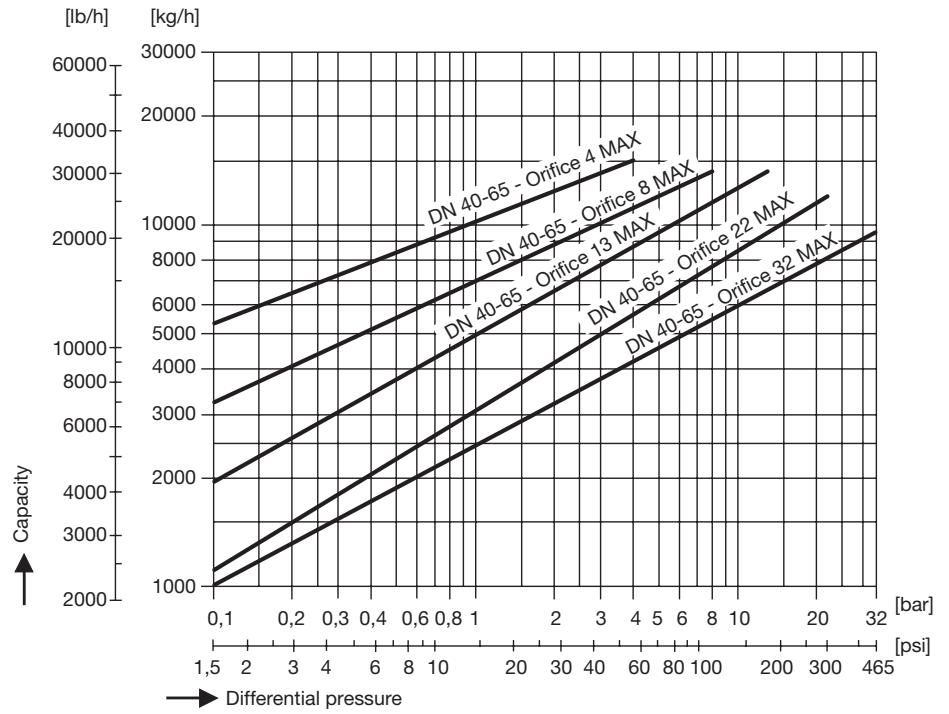

Capacity chart for cold water

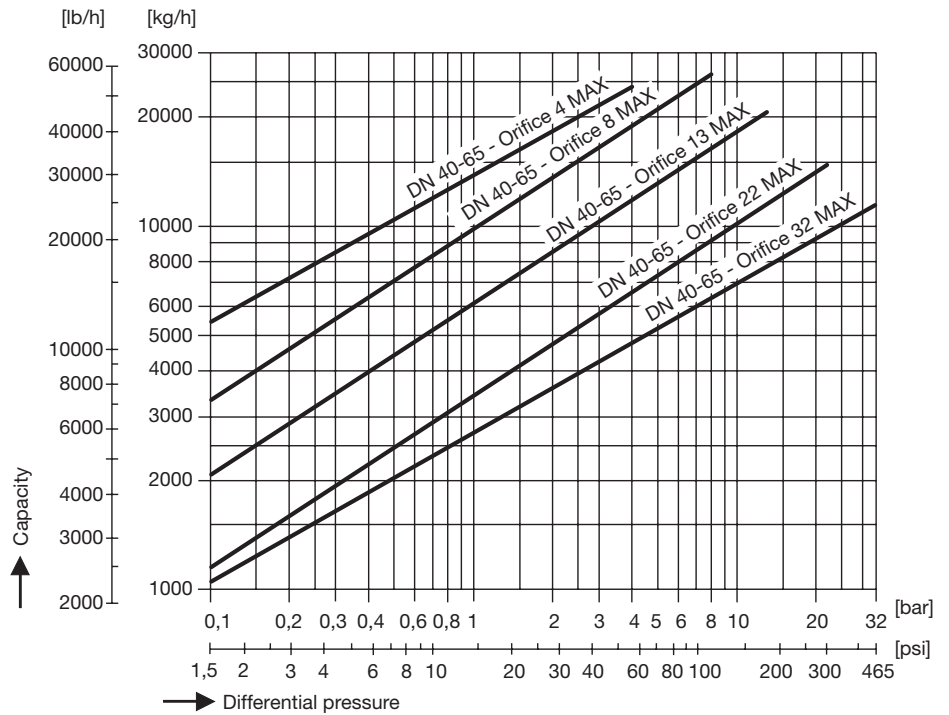

Ball Float Steam Trap
**UNA 45 MAX, UNA 46 MAX,
 UNA 46A MAX**
PN 40/Class 300
DN 40, 50, 65

Inspection & Certification

Documentation regarding material tests and in-house examination with test report EN10204 available. All inspection requirements have to be stated with the enquiry or order. After supply of the equipment certification cannot be established. Charges and extent of the above mentioned test certificates as well as the different tests confirmed therein are listed in our Price List "Test and Inspection Charges for Standard Equipment". For other tests and inspections than those listed above, please consult us.

Application of European Directives

Pressure Equipment Directive

The equipment conforms to this directive and can be used for the following media:

UNA 45 MAX

► Fluids of group 2

UNA 46 MAX and UNA 46A MAX

► Fluids of group 1

► Fluids of group 2

ATEX Directive

The equipment does not have its own potential ignition source and is not subject to this directive.

When installed, static electricity may arise between the equipment and the connected system. When used in potentially explosive atmospheres, the plant manufacturer or plant operator is responsible for discharging or preventing possible static charge.

If it is possible for medium to escape, e.g. through actuating mechanisms or leaks in threaded joints, the plant manufacturer or plant operator must take this into consideration when dividing the area into zones.

Spare Parts

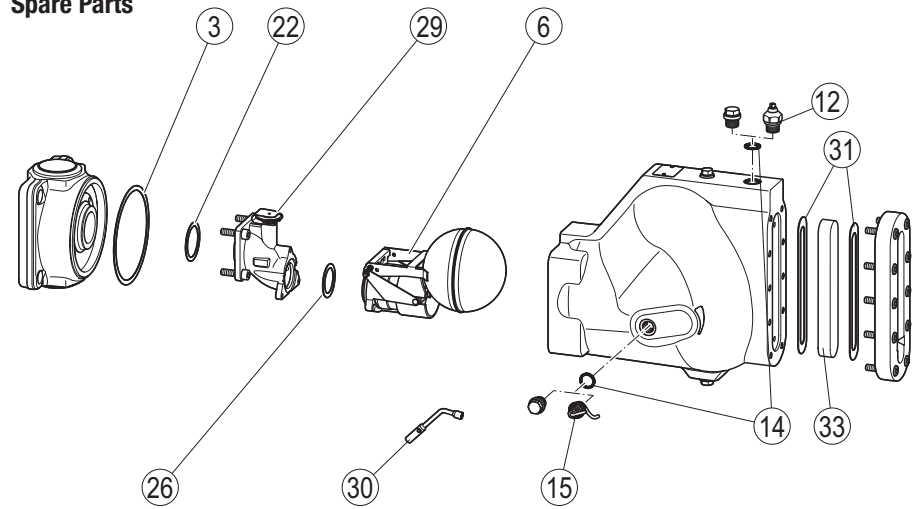

Item no.	Designation	Orifice	Stock code #		
			Standard cover	Sightglass cover	Cover for mounting electrodes
3, 6 22 26	Control unit, complete with body gasket, adapter gasket and gasket for control unit	4	560690		
		8	560691		
		13	560692		
		22	560693	–	560693
		32	560694	–	560694
3, 29	Membrane regulator capsule 5N2, cpl. with body gasket	all	560687		
12, 14 30	Hand-vent valve, cpl. with joint ring and socket spanner	all	560676	–	
14, 15 30	Float lifting lever, cpl. with joint ring and socket spanner	all	560678		
3	Body gasket ¹⁾	all	560680		
22	Adapter gasket ¹⁾	all	560682		
14	Gasket for sealing plug 3/8", float-lifting lever, hand-vent valve ¹⁾	all	560486 ²⁾ or 560514 ²⁾		
26	Gasket for control unit ³⁾	all	560547		
3, 14 22, 26	Gasket set ⁴⁾	all	560684	–	560684
30	Socket spanner	all	560700		
31, 33	Reflexion water level gauge with 2 gaskets	all	–	560480	–

1 Delivery quantity: 20 pcs

2 560486: Material 1.4301,
560514: Material 1.4571

3 Delivery quantity: 10 pcs

4 Contains:

4 gaskets 3/8"

1 body gasket

1 gasket for control unit

1 adapter gasket

Supply in accordance with our general terms of business.

GESTRA AG

Münchener Straße 77, 28215 Bremen, Germany
 Telefon +49 421 3503-0, Telefax +49 421 3503-393
 E-mail info@de.gestra.com, Web www.gestra.de

