



Conductivity Electrode

LRG 16-9

EN
English

Original Installation Instructions
818867-04

Contents

Page

Important notes

Usage for the intended purpose.....	4
Function.....	4

Important notes

Safety note.....	5
------------------	---

Directives and standards

Pressure Equipment Directive 2014/68/EU.....	6
VdTÜV Bulletin "Water Monitoring 100".....	6
Approvals for Marine Applications.....	6
ATEX (Atmosphère Explosible).....	6
UL/cUL (CSA) Approval.....	6
Note on the Declaration of Conformity / Declaration by the Manufacturer CE	6

Technical data

LRG 16-9.....	7
Scope of supply.....	7
Name plate / marking.....	7

Installation

Dimensions LRG 16-9.....	8
Mounting conductivity electrode.....	9
Key.....	9
Tools.....	9

Dimensions and examples of installation

LRG 16-910
LRG 16-911
Key11
LRG 16-912
Key12

Electrical connection

Connecting the conductivity electrode13
Leitfähigkeitselektrode LRG 16-9, Belegung Stecker - Buchse13

Troubleshooting

Indication, diagnosis and remedy14

Maintenance

Safety note.....15
Cleaning measuring electrode15

Removing and disposing of the conductivity electrode

Remove and discard conductivity electrode LRG 16-915

Important notes

Usage for the intended purpose

The conductivity electrode LRG 16-9 together with the conductivity switch LRS 1-.. or conductivity controller LRR 1-.. is designed for measuring and monitoring electrical conductivity in conductive fluids.

If used as conductivity limiter or continuous blowdown controller in steam boilers, the conductivity electrode LRG 16-9 can be used with the following equipment:

Conductivity switch LRS 1-7

Conductivity switch LRS 1-50

Conductivity controller LRR 1-50

Conductivity controller LRR 1-52

To guarantee a trouble-free operation observe the requirements made on water as specified in the pertinent TRD and EN regulations.

The equipment must only be used within the admissible pressure and temperature ratings.

Function

The conductivity electrode LRG 16-9 is used in combination with the following equipment as conductivity limiter and continuous blowdown controller in steam boilers:

Conductivity switch LRS 1-7

Conductivity switch LRS 1-50

Conductivity controller LRR 1-50

Conductivity controller LRR 1-52

In addition the equipment can measure conductivity in condensate and feedwater systems and in cooling and cleaning water.

The conductivity electrode LRG 16-9 in conjunction with conductivity switch LRS 1-7 is also approved for feedwater monitoring on board of seagoing vessels.

The conductivity electrode works in conjunction with conductivity switches or controllers and monitors the conductivity in conductive fluids.

To measure the fluid temperature a resistance thermometer Pt 100 is integrated in the electrode.

A short circuit or wire breakage in the conductivity electrode will trigger an error message in the conductivity switch or controller.

Important notes

- continued -

Safety note

The equipment must only be installed, wired and commissioned by qualified and competent staff. Retrofitting and maintenance work must only be performed by qualified staff who - through adequate training - have achieved a recognised level of competence.



Danger

When loosening the conductivity electrode steam or hot water might escape!
This presents the risk of severe scalding all over the body!
It is therefore essential not to dismantle the electrode unless the boiler pressure is verified to be 0 bar.

The conductivity electrode becomes hot during operation.
Risk of severe burns to hands and arms.
Before carrying out installation and maintenance work make sure that the equipment is cold.



Attention

The name plate specifies the technical features of the equipment. Do not commission or operate any item of equipment that does not bear its specific name plate.

Directives and standards

Pressure Equipment Directive 2014/68/EU

The conductivity control and monitoring equipment LRG 1.-..., LRS 1.-..., LRR 1-5. meet the safety requirements of the Pressure Equipment Directive (PED). The conductivity control & monitoring equipment is EC type approved according to EN 12952/EN 12953. These Directives state, among other things, the requirements made on limiting systems and equipment for steam boiler plants and (pressurised) hot-water installations.

VdTÜV Bulletin "Water Monitoring 100"

The conductivity electrode LRG 16-9 in conjunction with the following conductivity switches and controllers is type approved according to VdTÜV Bulletin "Water Level 100": LRS 1-7, LRS 1-50, LRR 1-50 and LRR 1-52.

The VdTÜV Bulletin "Water Monitoring 100" states the requirements made on water monitoring equipment.

Approvals for Marine Applications

The conductivity electrode LRG 16-9 in conjunction with conductivity switch LRS 1-7 is approved for feedwater monitoring on seagoing vessels. See data sheet.

ATEX (Atmosphère Explosible)

The equipment is a simple item of electrical equipment according to DIN EN 50020 section 5.4. According to the European Directive 2014/34/EU the equipment must be equipped with approved Zener barriers if used in potentially explosive areas. Applicable in Ex zones 1, 2 (1999/92/EC). The equipment is not Ex marked.

UL/cUL (CSA) Approval

The equipment complies with the requirements of the following standards: UL 508 and CSA C22.2 No. 14-13, Standards for Industrial Control Equipment. File E243189.

Note on the Declaration of Conformity / Declaration by the Manufacturer **CE**

For details on the conformity of our equipment according to the European Directives see our Declaration of Conformity or our Declaration of Manufacturer.

The current Declaration of Conformity and Declaration of Manufacturer are available in the Internet under www.gestra.com → documents or can be requested from us.

Technical data

LRG 16-9

Service pressure

PN 40, 32 bar at 238°C

Mechanical connection

Screwed G ½ A, ISO 228 (NPT also available)

Materials

Screw-in body: 1.4571, X6CrNiMoTi17-12-2

Measuring electrode: 1.4571, X6CrNiMoTi17-12-2

Electrode rod insulation: PEEK

Cell constant

0.5 cm⁻¹

Electrical connection

M 12 sensor connector, 5 poles, A coded

Protection

IP 65 to DIN EN 60529

Ambient temperature

Max. 70°C

Weight

Approx. 0.3 kg

Approvals:

TÜV certificate

VdTÜV Bulletin "Wasserüberwachung 100" (= Water Monitoring 100):

Requirements made on water monitoring equipment

Type approval: TÜV · WÜL · XX-014, XX-017, XX-018 (see name plate)

UL/cUL (CSA) Approval

UL 508 and CSA C22.2 No. 14-13, Standards for Industrial Control Equipment. File E243189.

Marine applications

In accordance with Germanischer Lloyd Directive GL 60444-09 HH

Scope of supply

LRG 16-9

1 Conductivity electrode LRG 16-9

1 Joint ring 21 x 26, form D, DIN 7603, 1.4301, bright annealed

1 Installation manual

Name plate / marking

Equipment designation

LRG 16-9		Pressure rating, thread type, material number, protection	
PN 40	G 1/2"	1.4571	IP 65
32 bar	238°C	T amb = 70°C	Mat-Nr: xxxxxx
TÜV · WÜL · XX-014 / XX-017 / XX-018			
GESTRA AG · Münchener Straße 77 · D-28215 Bremen			
Manufacturer		Service pressure & temperature, admissible ambient temp.	

Type approval no.

Fig. 1

Installation

Dimensions LRG 16-9

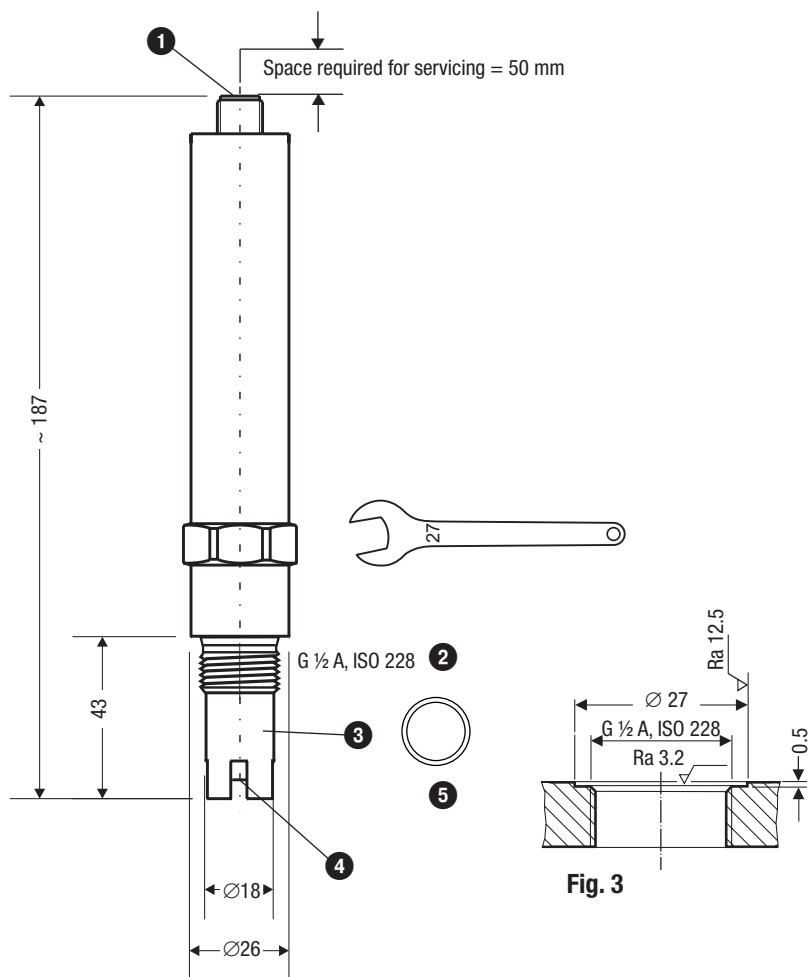

Fig. 2 LRG 16-9



Note

- The conductivity electrode is designed for installation in pipes.
- The conductivity electrode is installed in a socket end, a measuring chamber or a mounting flange.
- When installing the conductivity electrode please consider a min. space of 50 mm required for servicing and removing the conductivity electrode.



Attention

- Install conductivity electrode horizontally or with a vertical inclination. The measuring surface must be permanently submerged.
- Make sure that the sealing surface of the screwed connection is accurately machined.
- Use only the supplied ring joint 21 x 26, form D, DIN 7603, made from 1.4301, bright annealed!
- Do not insulate electrode thread with hemp or PTFE tape!
- Do not apply conductive paste or grease to the electrode thread!
- Observe the specified tightening torque.
- Leave a space of **approx. 15 mm** between the lower end of the measuring tube and the wall of the pipe.
- Do not cut the measuring electrode and the measuring tube!

Mounting conductivity electrode

1. Check seating surfaces. **Fig. 3**
2. Place supplied joint ring **③** onto seating surface of the threaded standpipe or flange.
3. Apply a light smear of heat resistant silicone grease (e. g. WINIX® 2150) to the electrode thread **③**.
4. Screw conductivity electrode into threaded standpipe and tighten with an open-end spanner A. F. 27 mm. The torque required for tightening **when cold is 110 Nm**.

Key

- ①** M 12 Sensor connector, 5 poles, A coded
- ②** Electrode thread G ½ A, ISO 228
- ③** Measuring tube
- ④** Measuring surface
- ⑤** Joint ring 21 x 26 form D to DIN 7603, made from 1.4301, bright annealed

Tools

- Open-end spanner 27 mm A. F.

Dimensions and examples of installation

LRG 16-9

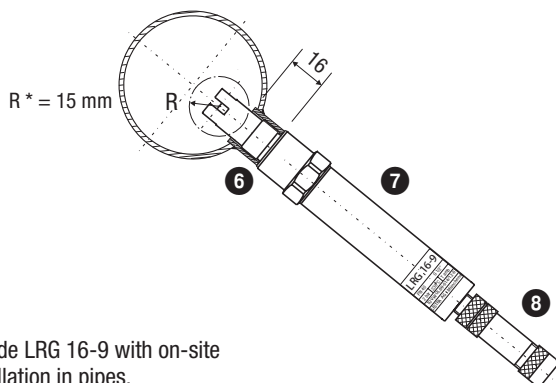

Fig. 4

Conductivity electrode LRG 16-9 with on-site socket end for installation in pipes.

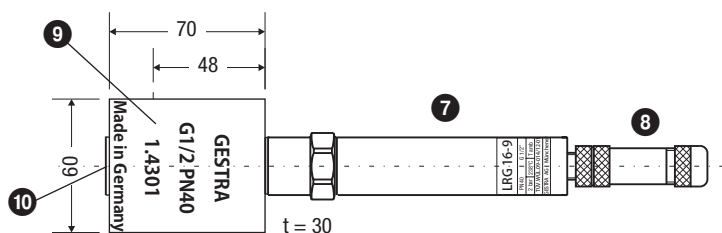

Fig. 5

Conductivity electrode LRG 16-9 with measuring chamber for installation in pipes.

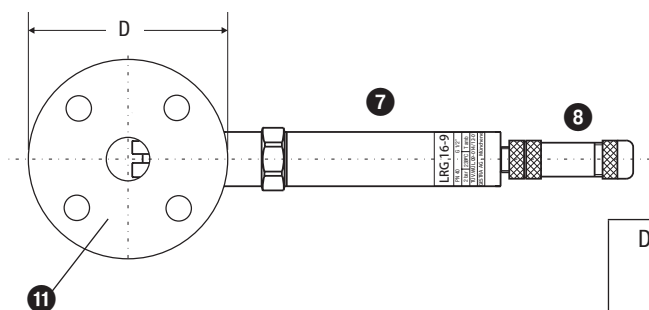

Fig. 6

Conductivity electrode LRG 16-9 with mounting flange for sandwiching between flanges.

DN	Flange diameter D	Thickness of flange
15	95	32
20	105	32
25	115	32
40	150	32

LRG 16-9

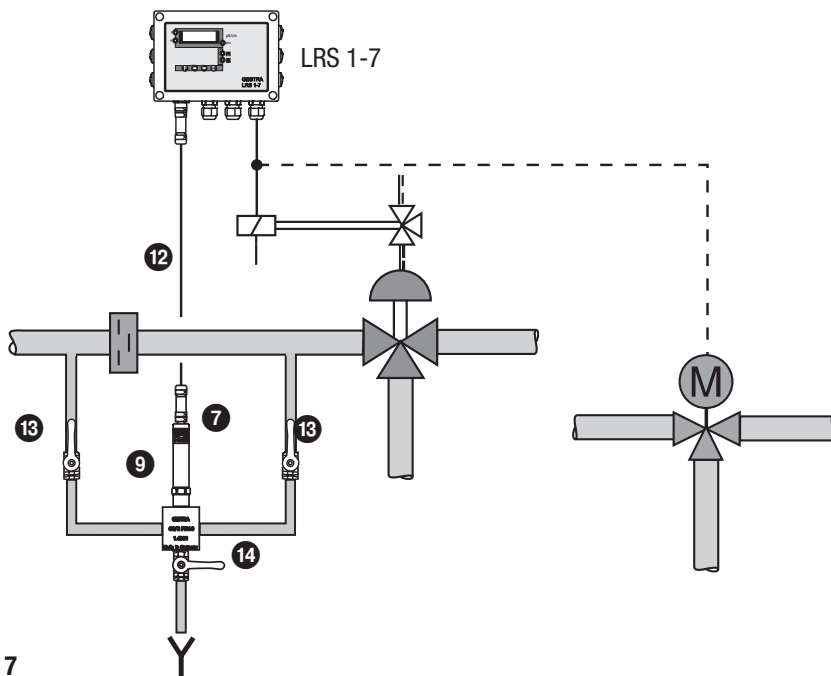

Fig. 7

Conductivity electrode LRG 16-9 with measuring chamber for installation in a bypass



Important Notes

- The conductivity electrode is mounted in a bypass below the main line. This arrangement prevents gas bubbles and flash steam from reaching the equipment. **Fig. 7**
- A throttling point, e. g. a non-return valve (GESTRA type RK 86) should be installed in the main line.
- To prevent air and dirt particles from getting into the bypass make sure that the bypass is below the main line.

Key

- | | |
|--|---|
| <p>6 Socket end to EN 10241, heavy design, screwed G½ A to ISO 228, length 16 mm, provided on site</p> | <p>11 Mounting flange PN 40, DIN EN 1092-01 with female thread G½</p> |
| <p>7 Conductivity electrode LRG 16-9</p> | <p>12 Non-return valve</p> |
| <p>8 Female connector (not supplied)</p> | <p>13 Ball valve G½</p> |
| <p>9 Measuring chamber, G½, PN 40, made from 1.4301</p> | <p>14 Ball valve G¾</p> |
| <p>10 Drain plug</p> | |

LRG 16-9

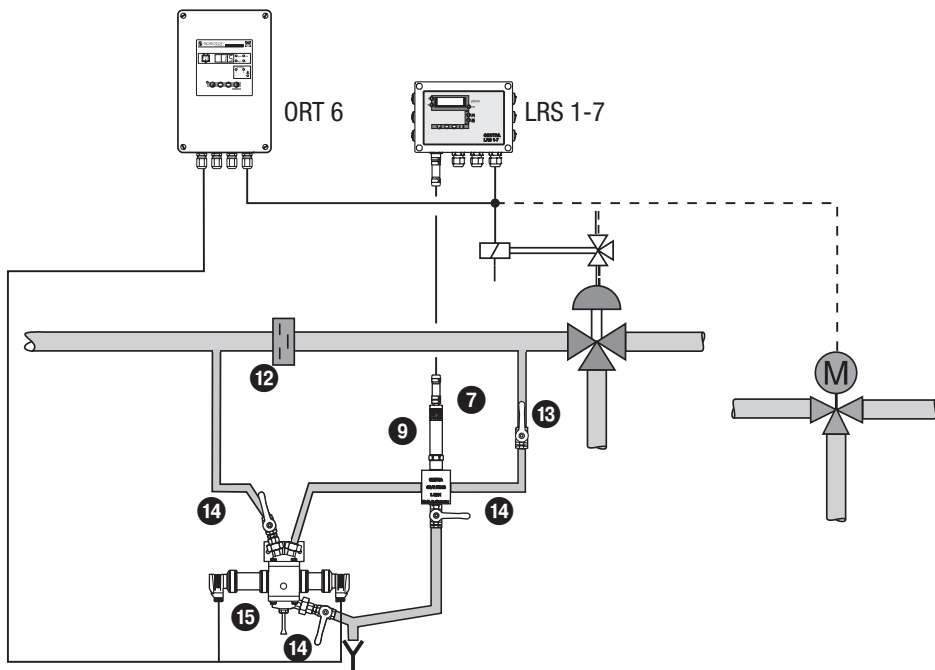

Conductivity electrode LRG 16-9 with measuring chamber for installation in a bypass together with the measuring sensor ORG 12 / 22 of the oil & turbidity detector OR 52-5 / OR 52-6.



Important Notes

- The conductivity electrode together with the measuring transducer ORGG 12 / 22 is mounted in a bypass below the main line. This arrangement prevents gas bubbles and flash steam from reaching the equipment. Please see also installation instructions for OR 52-5 / OR 52-6. **Fig. 8**
- A throttling point, e. g. a non-return valve (GESTRA type RK 86) should be installed in the main line.
- To prevent air and dirt particles from getting into the bypass make sure that the bypass is below the main line.

Key

- | | |
|---|---------------------------------|
| ⑦ Conductivity electrode LRG 16-9 | ⑭ Ball valve G 3/8 |
| ⑨ Measuring chamber, G 1/2, PN 40, 1.4301 | ⑮ Measuring sensor ORG 12 / 22 |
| ⑫ Non-return valve | ⑯ Resistance thermometer Pt 100 |
| ⑬ Ball valve G 1/2 | ⑰ Measuring electrode |

Electrical connection

Connecting the conductivity electrode

The conductivity electrode LRG 16-9 is equipped with a sensor plug-in connection type M 12, with 5 poles, A-coded, pin assignment see **Fig. 9**. For connecting the electrode preconfigured control cable assemblies (with male and female connectors) of various lengths are available as add-on equipment.

Note that the recommended control cable is not UV resistant and, if installed outdoors, must be protected by a UV resistant plastic tube or cable duct.

If you do not use the prefabricated control cable assembly, use screened five-core control cable, e. g. LiYCY 5 x 0.5 mm², for connecting the equipment. In addition, connect at the electrode end a screened female connector to the control cable.

Max. cable length between conductivity electrode and switch or controller: 30 m, with conductivities from 1 to 10 µS/cm: max. 10 m.

Conductivity electrode LRG 16-9, pin assignment

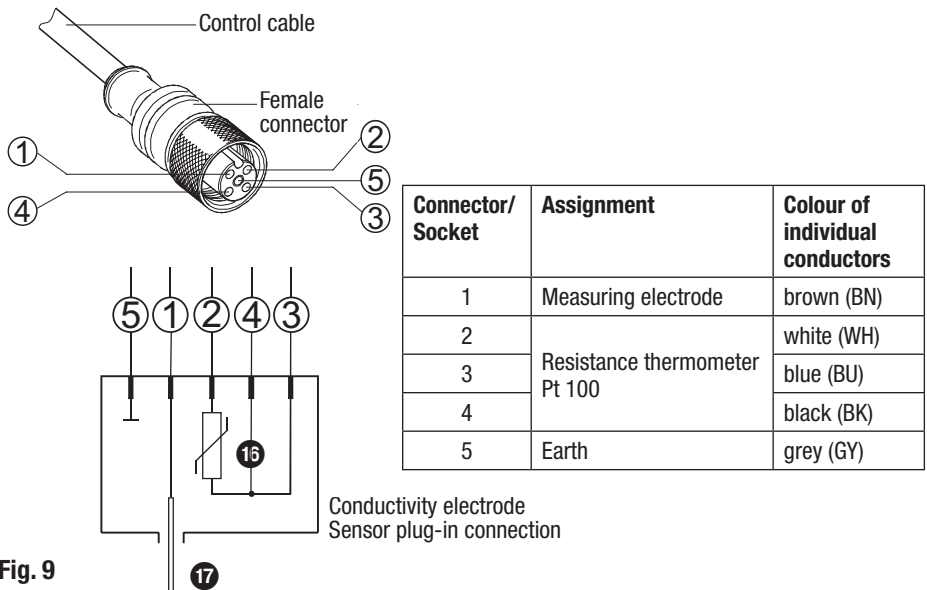

Fig. 9



Attention

- If the above-mentioned control cable assembly is not used, the connecting line must be provided with a screened female connector according to the wiring diagram. **Fig. 7**. Observe the mounting instructions of the connector manufacturer.
- Make sure that connecting cables leading to the equipment are segregated and run separately from power cables.
- Connect screens according to the installation instructions for the conductivity switches/controllers LRS 1-7, LRS 1-50, LRR 1-50 and LRR 1-52.

Troubleshooting

Indication, diagnosis and remedy



Attention

Before carrying out the fault diagnosis please check:

Supply voltage:

Is the conductivity switch / controller supplied with the mains voltage specified on the name plate?

Wiring:

Is the wiring in accordance with the wiring diagram?

Indication of malfunctions	
Conductivity switch / controller does not work accurately.	
Error	Remedy
Indicated conductivity reading is larger than the measured reference value.	Increase temperature coefficient tC during commissioning. Reduce correction factor CF during operation.
Indicated conductivity reading is smaller than the measured reference value.	Reduce temperature coefficient tC during commissioning. Increase correction factor CF during operation.
Measuring result cannot be adjusted by changing the correction factor.	Remove conductivity electrode and clean measuring surface.

Conductivity switch / controller does not work	
Error	Remedy
Power failure.	Switch on supply voltage. Check all electrical connections.
The earth connection to the vessel is interrupted.	Clean seating surfaces and screw in the conductivity transmitter together with the joint ring 21 x 26, form D, DIN 7603 (made from 1.4301), bright annealed. Do not insulate the electrode with hemp or PTFE tape!
Conductivity electrode defective, measured value too low. Electrode lines interrupted or measuring surface exposed.	Check connection of electrode lines. If necessary, replace equipment. Check water level and installation.
Conductivity electrode defective, measured value too high. Short circuit in electrode lines.	Check connection of electrode lines. If necessary, replace equipment.
Temperature sensor defective, temperature reading too low.	Check conductivity electrode LRG 16-9 and, if necessary, replace it with a new one. Check wiring (short circuit, interruption?)
Temperature sensor defective, temperature reading too high.	



Attention

- For commissioning and troubleshooting also observe the installation & operating manuals for LRS 1-7, LRS 1-50, LRR 1-50 and LRR 1-52.

Maintenance

Safety note

The equipment must only be installed, wired and commissioned by qualified and competent staff. Retrofitting and maintenance work must only be performed by qualified staff who - through adequate training - have achieved a recognised level of competence.



Danger

When loosening the conductivity electrode steam or hot water might escape! This presents the risk of severe scalding all over the body! It is therefore essential not to dismantle the conductivity electrode unless the boiler pressure is verified to be 0 bar.

The conductivity electrode becomes hot during operation.

Risk of severe burns to hands and arms.

Before carrying out installation and maintenance work make sure that the equipment is cold.

Cleaning measuring electrode

1. Detach sensor sleeve from the conductivity electrode.
2. Before removing the equipment make sure that it is neither hot nor under pressure.

Cleaning the measuring electrode (measuring surface):

- Wipe off non-adhesive deposits with a grease-free cloth.
- To remove adhesive deposits use emery cloth (medium grain).

Re-install the conductivity electrode. Observe the notes given in section "Installation" and "Electrical Connection".

Removing and disposing of the conductivity electrode

Remove and discard conductivity electrode LRG 16-9

1. Detach sensor sleeve from the conductivity electrode.
2. Before removing the equipment make sure that it is neither hot nor under pressure.

For the disposal of the equipment observe the pertinent legal regulations concerning waste disposal.

If faults occur that are not listed above or cannot be corrected, please contact our service centre or authorized agency in your country.



Agencies all over the world: www.gestra.de

GESTRA AG

Münchener Straße 77

28215 Bremen

Germany

Telefon +49 421 3503-0

Telefax +49 421 3503-393

E-mail info@de.gestra.com

Web www.gestra.de