

Drain Module

QuickEM QuickEM Control

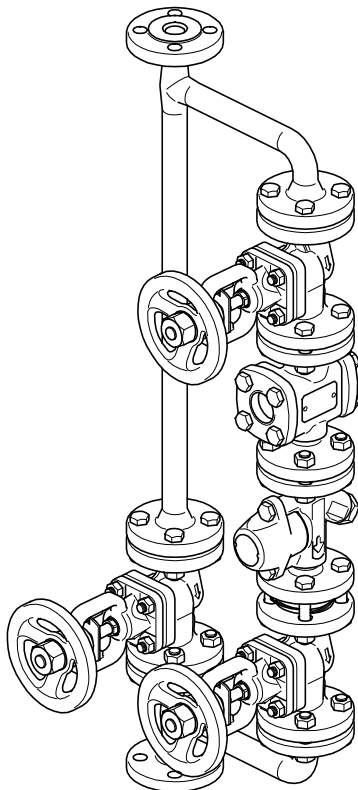

Contents

Foreword	3
Availability.....	3
Applicable documents.....	3
Formatting features in the document	3
Safety	4
Use for the intended purpose	4
Basic safety notes	4
Information on property damage or malfunctions	5
Qualification of personnel.....	5
Protective gear	5
Typographic features of warning notes.....	6
Formatting features for warnings of property damage	6
Description	6
Scope of supply and equipment specification	6
Application of European Directives	10
Task and function	10
Storing and transporting the equipment	11
Storing the equipment	11
Transporting the equipment	11
Mounting and connecting the equipment	12
Preparing installation	12
Connecting the equipment	12
Operation	13
After operation	14
Removing external dirt deposits	14
Maintaining the equipment.....	15
Servicing the equipment and installing spare parts	15
Troubleshooting	16
Putting the equipment out of operation	16
Removing harmful substances.....	16
Removing the equipment	16
Re-using equipment after storage.....	16
Disposing of the equipment.....	17
Technical data	18
Dimensions and weights	18
Pressure & temperature ratings.....	22
Manufacturer's declaration	23

Foreword

This installation & operating manual will help you use the following types of drain modules safely and efficiently for their intended purpose:

- ▶ QuickEM
- ▶ QuickEM Control

These drain modules will be called equipment in this document.

This installation & operating manual is intended for anyone commissioning, using, operating, servicing, cleaning or disposing of this equipment and, in particular, for professional after-sales service technicians, qualified personnel and authorised and trained staff.

All of these persons must read and understand the content of this installation & operating manual.

Following the instructions given in this installation & operating manual helps avoiding danger and increases the reliability and service life of the equipment. Please note that in addition to the instructions given in this installation & operating manual you must also observe all locally applicable rules and regulations concerning the prevention of accidents as well as approved safety guidelines for good professional practice.

Availability

Keep this installation & operating manual together with the plant documentation for future reference.

Make sure that this installation & operating manual is available to the operator.

The installation & operating manual is part of the equipment. Please hand over this installation & operating manual when selling the equipment or passing it on.

Applicable documents

For more information and further instructions regarding the components built into the equipment refer to their individual installation & operating manuals. These documents are to be regarded as part of this installation & operating manual and must be kept in a safe place for future reference. Please hand over these documents when selling the equipment or passing it on.

Formatting features in the document

Certain text elements of this installation & operating manual feature a specific typographic design. You can easily distinguish the following text elements:

Standard text

Cross-reference

- ▶ Listing
 - ▶ Sub-items in listings
- Steps for action.



Here you will find additional useful information and tips serving to assist you in using the equipment to its fullest potential.

Safety

Use for the intended purpose

The following types of equipment are designed to discharge condensate from steam systems:

- ▶ QuickEM
- ▶ QuickEM Control

QuickEM Control is also designed for monitoring steam traps for banking-up of condensate and loss of live steam.

Use measuring electrodes NRG 16-27 and NRG 16-28 only in conjunction with suitable analysing devices (e. g. GESTRA test station NRA 1-3). Suitable analysing devices are specified in the operating manuals of the respective measuring electrodes.

The equipment must only be used within the allowable pressure and temperature limits and only if the chemical and corrosive influences on the equipment are taken into account.

Correct use includes compliance with the instructions given in this installation & operating manual, in particular obedience to all safety instructions.

Any other use of the equipment is considered to be improper.

In particular any kind of refitting or modification of the equipment without prior approval of the manufacturer is regarded as improper use.

Note that the equipment is also used incorrectly if the materials of the equipment are not suitable for the fluid.

Basic safety notes

Explosion hazard

- ▶ Risk of explosion caused by static electricity if the equipment is improperly mounted in potentially explosive areas!
Observe all safety standards for fire and explosion prevention prescribed for the place of installation.
The equipment and its component parts must only be mounted or removed by qualified personnel.
Make sure that any static electricity is discharged.

Risk of severe injuries

- ▶ The equipment is under pressure during operation and may be hot. Before carrying out any work on the equipment make sure that the following requirements are met:
 - ▶ The pipes must be depressurized (0 bar).
 - ▶ The fluid must be completely removed from the pipes and the equipment.
 - ▶ During work on the equipment the installation must be switched off and protected against unauthorised or unintended activation.
 - ▶ The pipes and the equipment must have cooled down to room temperature (approx. 20 °C).
- ▶ If the equipment is used in contaminated areas there is a risk of severe injuries or death caused by harmful substances in or on the equipment. Before working on the equipment make sure that it is completely decontaminated. Always wear the protective clothing prescribed for contaminated areas when working on the equipment.
- ▶ The equipment must only be used with fluids that do not attack the material and the gaskets and sealings of the equipment. Otherwise leaks may occur and hot or toxic fluid could escape.
- ▶ The equipment and its component parts must only be mounted or removed by qualified personnel. A qualified person must be

acquainted with and experienced in the following:

- ▶ Making pipe connections.
- ▶ Selecting suitable lifting gear and understanding the rules for its safe use.
- ▶ Working with dangerous (contaminated, hot or pressurized) fluids.
- ▶ If the admissible temperature and pressure limits are exceeded the equipment may be destroyed and hot or pressurized fluid may escape. Make sure that the equipment is only operated within the admissible service range and limits.
For more information on pressure and temperature ratings see name plate or refer to the respective operating manual of the component part.

Risk of minor injuries

- ▶ Sharp edges on internals present the danger of cuts to hands. Always wear industrial gloves when servicing the equipment.
- ▶ If the support of the equipment during installation is insufficient the equipment might fall down, thereby causing bruises or injuries. Make sure the equipment is safely held in place during installation and cannot fall down. Wear protective safety footwear.
- ▶ Risk of bruises or injuries if you touch moving parts inside the equipment. Never touch any moving parts! Wear sturdy protective gloves.

Information on property damage or malfunctions

- ▶ Malfunctions will occur if the equipment is installed in a wrong position or with the flow pattern in the opposite direction of the fluid flow. This may result in damage to the equipment or the installation. Observe the flow direction arrow on the equipment body and make sure it matches the direction of the fluid flow in the pipe when installing the equipment.
- ▶ If the material is unsuitable for the fluid, increased wear may occur and fluid may escape. Make sure that the material is suitable for the fluid used in your installation.

Qualification of personnel

A qualified person must be acquainted with and experienced in the following:

- ▶ the pertinent on-site rules and regulations for preventing fire and explosions as well as industrial safety regulations
- ▶ working on pressure equipment
- ▶ making pipe connections
- ▶ working with dangerous (hot or pressurized) fluids
- ▶ lifting and transporting loads
- ▶ observing all notes and instructions in this installation & operating manual and the applicable documents

Protective gear

The operator must ensure that anyone working on the equipment must wear the required protective clothing and safety gear stipulated for the site of installation. The protective clothing must be suitable for the used media and must protect the wearer against safety and health hazards associated with a particular job to be carried out at the site of installation. Protective clothing & equipment must provide protection from potential hazards, in particular from injuries to:

- ▶ Head
- ▶ Eyes
- ▶ Body
- ▶ Hand
- ▶ Feet
- ▶ Hearing

Note that this list is not exhaustive. The operator must establish personal protective equipment guidelines and specify any additional protective gear that is required if the worker is exposed to a specific risk at the site of installation.

Typographic features of warning notes



DANGER

Notes with the heading DANGER warn against imminent dangerous situations that can lead to death or serious injuries.



WARNING

Notes with the heading WARNING warn against possibly dangerous situations that could lead to death or serious injuries.



CAUTION

Notes with the heading CAUTION warn against dangerous situations that could lead to minor or moderate injuries.

Formatting features for warnings of property damage

Attention!

This information warns of a situation leading to property damage.

Description

Scope of supply and equipment specification

Scope of supply

Our equipment is delivered packed and ready for assembly.

The pipe connections are provided with caps to protect them against contamination.

Following items are supplied:

- the equipment
- this installation & operating manual
- the installation & operating manuals of all components built into the equipment

Note that neither any parts required for installing the equipment (such as counter flanges, screws, bolts or gaskets) nor the test station necessary for evaluating the measurement results of QuickEM Control are part of the delivery.

Equipment specification

The drain module consists of several components and combines all necessary functions in one item of equipment:

- a steam trap for discharging condensate
- shut-off valves on either side of the trap for isolating the trap
- a non-return valve prevents the fluid from flowing back
- a branch line for bypassing the fluid if the steam trap is shut off
- a sightglass for visual indication of flow and steam trap performance
- a measuring electrode (only fitted in QuickEm Control) for checking steam trap performance



This installation manual shows equipment mounted with bypass in horizontal position. The text will indicate if the equipment can also be installed in a vertical position.

QuickEM

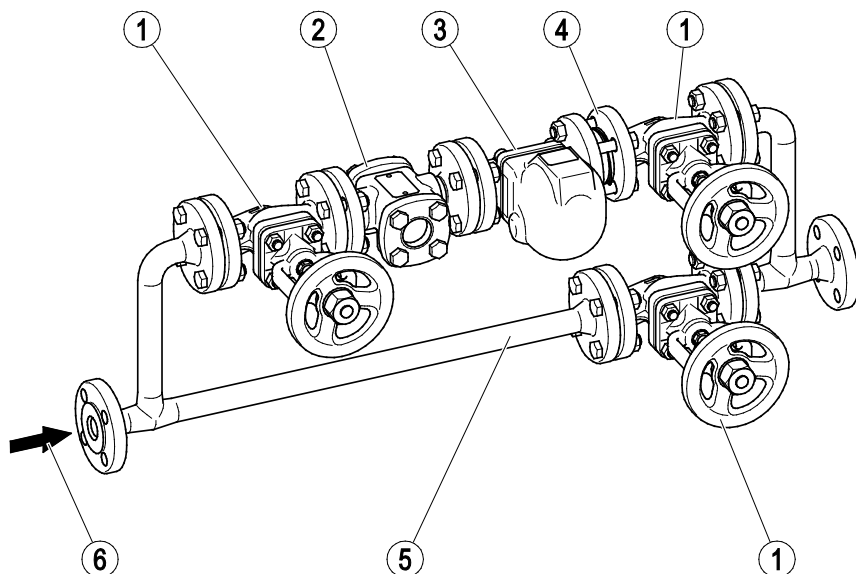

Item no.	Designation
1	Shut-off valve
2	Sightglass
3	Steam trap ¹

Item no.	Designation
4	Non-return valve
5	Bypass
6	Direction of flow

- 1 The following types of steam trap (3) are possible:
- ▶ UNA
 - ▶ BK (not shown)
 - ▶ MK (not shown)

The equipment can be installed in horizontal position. A special version for vertical installation with downward flow is optionally available.

QuickEM Control

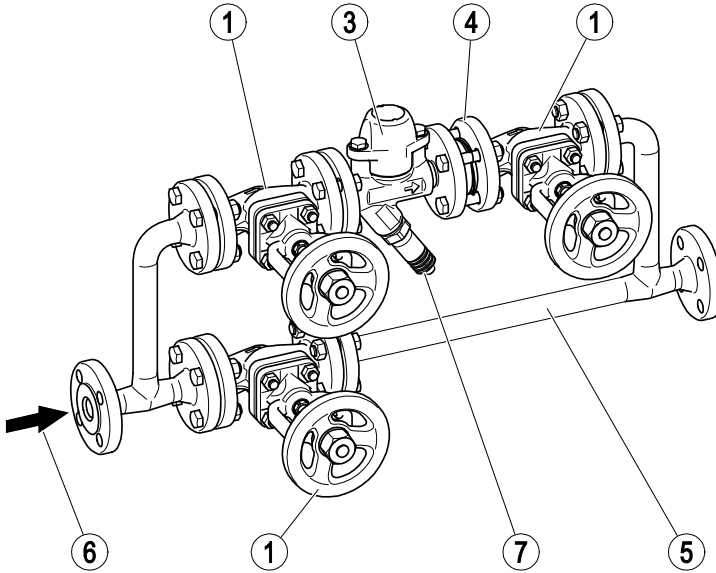

Item no.	Designation
1	Shut-off valve
3	Steam trap ¹
4	Non-return valve

Item no.	Designation
5	Bypass
6	Direction of flow
7	Measuring electrode (attached to steam trap)

- 1 The following types of steam trap (3) are possible:
- ▶ BK 45 with measuring electrode NRG 16-28 (horizontal and vertical position of installation)
 - ▶ MK 45 with measuring electrode NRG 16-28 (horizontal and vertical position of installation)
 - ▶ UNA 4 (DN40, DN50) with measuring electrode NRG 16-27 (horizontal position of installation, not shown)

QuickEM Control with test chamber

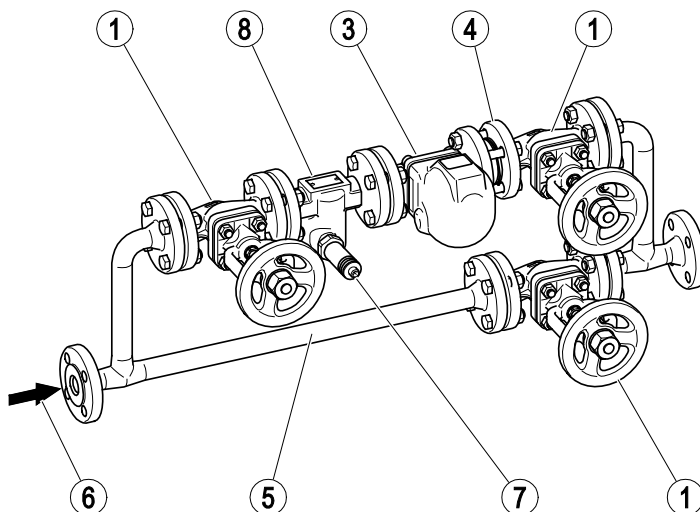

Item no.	Designation
1	Shut-off valve
3	Steam trap ¹
4	Non-return valve
5	Bypass

Item no.	Designation
6	Direction of flow
7	Measuring electrode
8	Test chamber

- 1 The following types of steam trap (3) are possible:
- ▶ UNA 1 (DN15–25) with measuring electrode NRG 16-27 (horizontal position of installation)
 - ▶ BK 15 with measuring electrode NRG 16-27 (horizontal position of installation, not shown)
 - ▶ MK 25 with measuring electrode NRG 16-27 (horizontal position of installation, not shown)

Name plate

The equipment does not have a nameplate. The nameplates of the individual components are described in the respective installation & operating manuals.

Application of European Directives

Pressure Equipment Directive

The equipment conforms to this directive (see "Manufacturer's Declaration" section) and can be used for the following media:

- ▶ Fluids of group 2

The CE markings of the individual components are described in the respective installation & operating manuals.

ATEX Directive

The equipment does not have its own potential ignition source and is not subject to this directive (see "Manufacturer's Declaration" section).

When installed, static electricity may arise between the equipment and the connected system.

When used in potentially explosive atmospheres, the plant manufacturer or plant operator is responsible for discharging or preventing possible static charge.

If it is possible for medium to escape, e.g. through actuating mechanisms or leaks in threaded joints, the plant manufacturer or plant operator must take this into consideration when dividing the area into zones.

QuickEM Control

QuickEM Control equipment must NOT be used in potentially explosive areas.

Task and function

Drain modules QuickEM and QuickEM Control are designed to discharge condensate from steam systems: For this purpose the drain module is equipped with a steam trap.

QuickEM Control is also designed for monitoring steam traps for banking-up of condensate and loss of live steam. For this purpose the equipment is fitted with a measuring electrode. The measuring electrode is either mounted in the steam trap or a test chamber. An additional test station, e. g. Test Station NRA 1-3, is required for evaluating the readings of the measuring electrode.

Two shut-off valves allow you to isolate the equipment so that you can carry out maintenance or service work on individual components.

The fluid can flow through the bypass when these shut-off valves are closed. During normal operation the shut-off valve in the bypass line can be closed to prevent the fluid from flowing through the bypass.

Storing and transporting the equipment

Attention!

Equipment can be damaged if stored or transported improperly.

- Close all openings with the sealing plugs or covers supplied with the equipment or use similar sealing covers.
- Protect the equipment against moisture and corrosive atmospheres.
- Please contact the manufacturer if the specified transport and/or storage requirements cannot be met.

Storing the equipment

- Please observe the following items when storing the equipment:
 - ▶ Do not store the equipment for more than 12 months.
 - ▶ Use the supplied sealing plugs or other suitable seal caps in order to seal off all openings of the equipment.
 - ▶ Protect the sealing surfaces and contact areas against mechanical damage.
 - ▶ Protect the equipment and all components against hard shocks and impacts.
 - ▶ Store the equipment only in closed rooms that meet the following environmental conditions:
 - ▶ Air humidity below 50 %, not condensing
 - ▶ Indoor air: clean, salt-free and non-corrosive
 - ▶ Temperature 5–40 °C.
- Make sure that all these requirements are always met when storing the equipment.
- Please contact the manufacturer if you cannot comply with the recommended storage conditions.

Transporting the equipment



CAUTION

Do not drop the equipment. If it falls down it may cause bruises and injuries.

- To transport and mount the equipment safely use suitable lifting gear.
- Connect a noose strap of the lifting gear to each end connection.
- Provide adequate support for the equipment during transport and installation.
- Wear protective safety footwear.

Lightweight equipment may be transported and mounted without using any lifting gear.

To lift equipment the weight of which exceeds approx. 25 kg, you need the help of a second person or suitable lifting gear.

Your physical strength and on-site regulations and conditions determine what weight can be lifted and if support is required.

Attention!

Shut-off valves may get damaged if the handwheels are used for lifting the equipment.

- Connect the lifting gear only to the end connections.
- Meet the requirements for storage also when transporting the equipment.
- Prior to transport seal off connections with sealing plugs.
-  If you do not have the sealing plugs supplied with the equipment use appropriate seal caps to seal off the connections.
- For short distances (only a few metres) you can transport the equipment unpacked.

- When transporting the equipment over larger distances use the original packaging.
- If you do not have the original packaging use a box that protects the equipment adequately against corrosion and physical damage.



For a short period of time the equipment may be transported even if the temperature is below 0 °C, provided that the equipment is completely empty and dry.

Mounting and connecting the equipment

Preparing installation

- Take the equipment out of the transport packaging.
- Check the equipment for transport damage.
- Contact the manufacturer if you detect any kind of shipping damage.

When supplied by the factory, the connections may be sealed off with sealing plugs.

- Remove sealing plugs before mounting the equipment.
- Keep the sealing plugs and the packing for further use.



DANGER

Personnel working on pipes are exposed to safety risks and may suffer severe injuries, poisoning or even loss of life.

- Make sure that no hot or hazardous fluid is in the equipment or the pipes.
- Make sure that the pipes upstream and downstream of the equipment are depressurised.
- Make sure that the installation is switched off and protected against unauthorised or unintended activation.
- Make sure that the equipment and the pipes have cooled down to room temperatures.
- Wear protective clothing that is suitable for the fluid and, if necessary, wear protective gear.

For more information on suitable protective clothing and safety gear refer to the safety data sheet of the fluid in question.

- Drain pipes until they are empty.
- Switch the installation off and protect it against unauthorised or unintended re-activation.

Connecting the equipment



DANGER

Incorrectly connected equipment can cause fatal accidents or severe injuries.

- Make sure that only qualified skilled personnel connect the equipment to pipes.
- Make sure that the flow arrows on the valves match the direction of flow in the pipe.

Specialist personnel must be highly qualified and fully experienced in making pipe connections for the respective type of end connection.



CAUTION

Do not drop the equipment. If it falls down it may cause bruises and injuries.

- To transport and mount the equipment safely use suitable lifting gear.
- Connect a noose strap of the lifting gear to each end connection.
- Provide adequate support for the equipment during transport and installation.
- Wear protective safety footwear.

Lightweight equipment may be transported and mounted without using any lifting gear.

To lift equipment the weight of which exceeds approx. 25 kg, you need the help of a second person or suitable lifting gear.

Your physical strength and on-site regulations and conditions determine what weight can be lifted and if support is required.

Attention!

Equipment will be damaged if the end connections are undersized.

- Make sure that the connections are strong and rigid enough to support the weight of the equipment and to withstand the forces that occur during operation.
- Make sure that the pipe system of the plant is clean.
- Make sure that the equipment is free from foreign matter.

Please observe the space required for servicing the individual components. For information on the required withdrawal distance see the respective operating manual for the component in question.

- Observe all specified withdrawal distances when mounting the equipment.

- Make sure that the flow arrow matches the direction of the fluid flow in the pipe.

The direction of flow is indicated by the arrow on the valves.

- Connect the end connections of the equipment properly to the pipes.
- Make sure that the equipment is safely mounted and that all connections are made correctly.
- In equipment type QuickEM Control connect the measuring electrode to the terminal strips of the test station.

Operation

- Before commissioning the equipment make sure that:

- ▶ all flanged connections of the equipment are tightly bolted together and leakproof.
- ▶ the measuring electrode is mounted correctly and in accordance with the wiring diagram.

All necessary specifications are indicated in the installation & operating manual of the respective component.

To remove contamination in the pipes you can use the bypass for rinsing. To do so proceed as follows:

- Close the shut-off valve upstream and downstream of the steam trap.
- Slowly open the shut-off valve of the bypass.

The medium flows now through the bypass, rinsing off any contaminants.

- Rinse until no more impurities come out.
- Close the shut-off valve of the bypass.
- Completely open the shut-off valve upstream and downstream of the steam trap.

The equipment is now ready for operation.

During operation no adjustments or service work on the equipment is required.

For more information on the operation of the individual components refer to the respective installation & operating manuals.



Caution

Risk of injuries if you touch parts of the installation during operation without wearing suitable protective clothing.

- Always wear protective clothing if you touch parts of the installation during operation.
- Observe and follow all instructions on protective clothing stated in all applicable documents and the safety data sheet for the fluid used.

Note that the handwheels of the shut-off valves in particular may be hot during operation.

After operation



DANGER

If fluid escapes personnel may suffer severe injuries, poisoning or even loss of life.

- After working on the equipment make sure that all connections and valves are tight.
- Make sure that the gaskets of the body are leakproof.



DANGER

Personnel working on pipes are exposed to safety risks and may suffer severe injuries, poisoning or even loss of life.

- Make sure that no hot or hazardous fluid is in the equipment or the pipes.
- Make sure that the pipes upstream and downstream of the equipment are depressurised.
- Make sure that the installation is switched off and protected against unauthorised or unintended activation.
- Make sure that the equipment and the pipes have cooled down to room temperatures.
- Wear protective clothing that is suitable for the fluid and, if necessary, wear protective gear.

For more information on suitable protective clothing and safety gear refer to the safety data sheet of the fluid in question.

Attention!

Frost damage may occur when the installation is shut down.

- Drain the equipment if ambient temperatures below 0 °C (frost) are to be expected.

Removing external dirt deposits

- To remove dirt deposits rinse the equipment with fresh water and wipe it with a clean, lint-free cloth.
- To remove any persistent residues use a cleaning agent that is suitable for the material and carefully wipe the equipment with a clean, lint-free cloth.

Maintaining the equipment

The equipment does not require any particular maintenance.

For more information on servicing and maintenance of the individual components refer to the respective installation & operating manuals.



Malfunctions may occur if the equipment is used with different types of condensate:

The following condensates in particular cause problems:

- very oily condensates
- condensates that resinify or become gummy
- condensates that recrystallize
- condensates that contain solid matter.

In these cases check the equipment at regular intervals for contamination and, if necessary, remove dirt deposits.

To reduce contamination we recommend installing a sedimentation vessel or a dirt pocket arrangement upstream of the equipment.

Servicing the equipment and installing spare parts

No spare parts are available for the equipment. For information on spare parts for the individual components refer to the respective installation & operating manuals.

Troubleshooting

Problem	Cause	Remedy
Fluid escapes (equipment is leaking).	The equipment or the body is damaged.	Replace the equipment with a new one.
Fluid escapes (equipment is leaking).	A gasket is damaged.	Replace the gasket with a new one. Clean gasket seating surfaces.
Fluid escapes (equipment is leaking).	The connections are not tight.	Provide the connections with leakproof seals.

For information on troubleshooting refer to the installation & operating manuals of the individual components.

- If faults occur that are not listed above or cannot be corrected, please contact our Technical Service or authorized agency in your country.

Putting the equipment out of operation

Removing harmful substances

- Remove all residues from the equipment.
- For the disposal of all residues observe the pertinent legal regulations concerning waste disposal.

Removing the equipment

- Store the equipment as described on page 11.

Re-using equipment after storage

Observe the following instructions if you want to remove the equipment and use it again somewhere else:

- ◆ Make sure that the equipment is free of any fluid residues.
- ◆ Make sure that all connections are in good condition and leak-free.
- Use the equipment only for its intended purpose and the service conditions for which it was specified.

Disposing of the equipment



Caution

Environmental damage may be caused by poisonous fluid residues.

- Before disposing of the equipment make sure that it is clean and free of fluid residues.
- For the disposal of all materials observe the pertinent legal regulations concerning waste disposal.

The equipment is made from the following materials:

Materials used in QuickEM, steel version

Component part	Material
Pipes and fittings	P235GH
Gaskets	PSM graphite with perforated steel insert
Hexagon-head bolts, nuts	5.6/5.2

Materials used in QuickEM, stainless steel version

Component part	Material
Pipes and fittings	1.4571
Gaskets	PSM graphite with perforated steel insert
Hexagon-head bolts, nuts	A2/70

For information on materials used for the individual components refer to the respective installation & operating manuals.

Technical data

Dimensions and weights

QuickEM with bypass

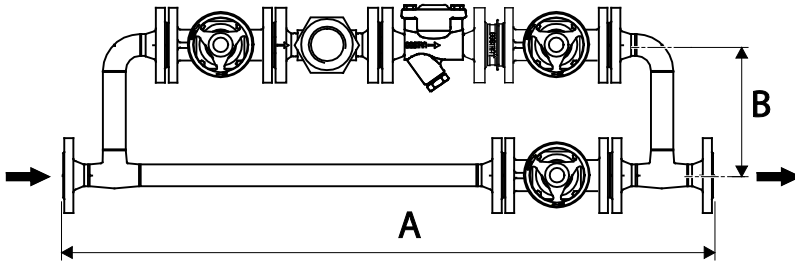

Steam trap type:				BK	MK	UNA	
DN			PN				
DN15	Dimensions [mm]	A	PN16	821			
			PN40	841			
	B	all	200				
	Weight [kg]		PN16	21	21	26	–
		PN40	25	25	–	27	
DN20	Dimensions [mm]	A	all	908			
		B	all	200			
	Weight [kg]		PN16	27	27	33	–
		PN40	31	31	–	34	
DN25	Dimensions [mm]	A	all	988			
		B	all	200			
	Weight [kg]		PN16	45	45	51	–
		PN40	49	49	–	53	
DN40	Dimensions [mm]	A	all	1,290			
		B	all	300			
	Weight [kg]		PN16	83	83	97	–
		PN40	82	82	–	96	
DN50	Dimensions [mm]	A	all	1,452			
		B	all	300			
	Weight [kg]		PN16	102	103	115	–
		PN40	101	102	–	114	

QuickEM without bypass

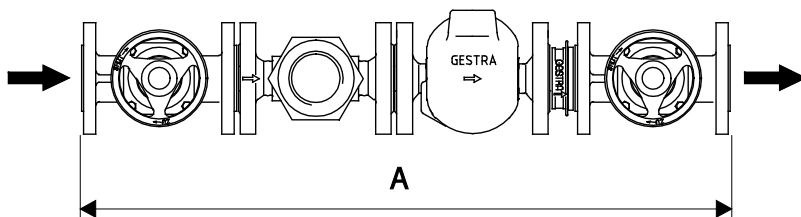

Steam trap type:			BK	MK	UNA		
DN		PN					
DN15	Dimensions [mm]	A	PN16	564			
			PN40	584			
	Weight [kg]		PN16	11	11	16	–
			PN40	14	14	–	17
DN20	Dimensions [mm]	A	all	627			
	Weight [kg]		PN16	14	14	20	–
			PN40	17	17	–	21
DN25	Dimensions [mm]	A	all	670			
	Weight [kg]		PN16	16	16	23	–
			PN40	20	20	–	23
DN40	Dimensions [mm]	A	all	870			
	Weight [kg]		PN16	50	50	64	–
			PN40	49	49	–	63
DN50	Dimensions [mm]	A	all	968			
	Weight [kg]		PN16	59	59	73	–
			PN40	58	58	–	72

QuickEM Control with bypass

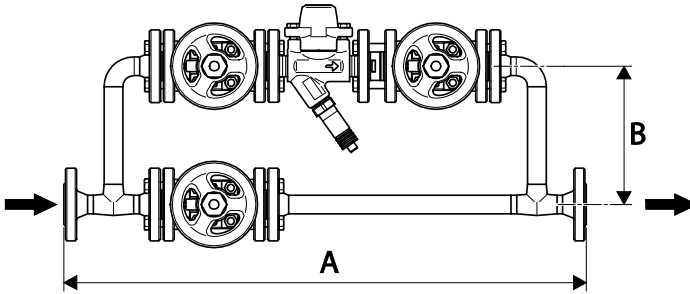

Steam trap type:				BK	MK	UNA	
DN		PN					
DN15	Dimensions [mm]	A	all	689	689	841	841
		B	all	250	250	200	200
	Weight [kg]		PN16	21	21	27	–
			PN40	21	21	–	27
DN20	Dimensions [mm]	A	all	756	756	908	908
		B	all	250	250	200	200
	Weight [kg]		PN16	27	27	33	–
			PN40	27	27	–	33
DN25	Dimensions [mm]	A	all	826	826	988	988
		B	all	300	300	200	200
	Weight [kg]		PN16	45	45	51	–
			PN40	45	45	–	51
DN40	Dimensions [mm]	A	all	1,320	1,320	1,090	1,090
		B	all	400			
	Weight [kg]		PN16	81	81	88	–
			PN40	80	80	–	87
DN50	Dimensions [mm]	A	all	1,452	1,452	1,222	1,222
		B	all	400			
	Weight [kg]		PN16	100	101	103	–
			PN40	99	100	–	102

QuickEM Control without bypass

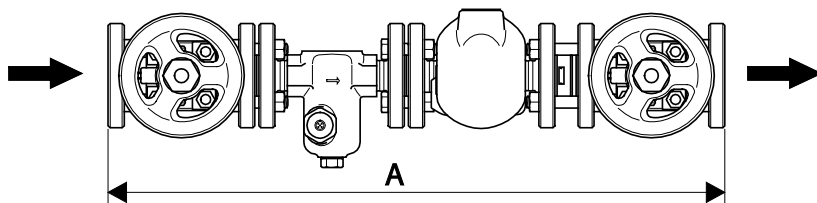

Steam trap type:				BK	MK	UNA	
DN			PN				
DN15	Dimensions [mm]	A	all	432	432	584	584
	Weight [kg]		PN16	11	11	17	–
			PN40	11	11	–	17
DN20	Dimensions [mm]	A	all	475	475	627	627
	Weight [kg]		PN16	14	14	20	–
			PN40	14	14	–	20
DN25	Dimensions [mm]	A	all	508	508	670	670
	Weight [kg]		PN16	16	16	22	–
			PN40	16	16	–	22
DN40	Dimensions [mm]	A	all	900	900	668	668
	Weight [kg]		PN16	46	47	50	–
			PN40	46	47	–	50
DN50	Dimensions [mm]	A	all	968	968	736	736
	Weight [kg]		PN16	55	56	56	–
			PN40	55	56	–	56

Pressure & temperature ratings

The following pressure, temperature and pH limits refer to equipment without sightglass. For information on limiting conditions for the individual components refer to the respective installation & operating manuals.

The lowest or highest limit of any component determines the decisive overall limiting conditions of the equipment.

Limiting conditions for steel version QuickEM PN16/QuickEM-Control PN16

pH value	≤ 9					
Pressure p	[barg]	16.0	14.4	12.8	11.2	9.6
Temperature T	[°C]	-10/20	100	200	250 ¹	280 ¹

- 1 If QuickEM Control together with measuring electrode NRG 16-27 or NRG 16-28 is used, the max. admissible temperature limit is 238 °C.

Limiting conditions for steel version QuickEM PN40/QuickEM-Control PN40

pH value	≤ 10					
Pressure p	[barg]	40.0	37,1	33,3	30,4	27,6
Temperature T	[°C]	-10/20	100	200	250 ¹	300 ¹

- 1 If QuickEM Control together with measuring electrode NRG 16-27 or NRG 16-28 is used, the max. admissible temperature limit is 238 °C.

Limiting conditions for stainless steel version QuickEM PN16/QuickEM Control PN16

pH value	≤ 7 ¹					
Pressure p	[barg]	16.0	12.5	10.0	9.0	9.0
Temperature T	[°C]	-10/20	100	200	250 ²	280 ²

- 1 Fluids with pH value above 7 have the potential to cause glass corrosion. As the temperature and pH value of the fluid increases, the possibility of etching the glass also increases.
- 2 If QuickEM Control together with measuring electrode NRG 16-27 or NRG 16-28 is used, the max. admissible temperature limit is 238 °C.

Limiting conditions for stainless steel version QuickEM PN40/QuickEM Control PN40

pH value	$\leq 7^1$					
Pressure p	[barg]	40.0	32.5	25.0	23.0	21.0
Temperature T	[°C]	-10/20	100	200	250 ²	280 ²

- 1 Fluids with pH value above 7 have the potential to cause glass corrosion. As the temperature and pH value of the fluid increases, the possibility of etching the glass also increases.
- 2 If QuickEM Control together with measuring electrode NRG 16-27 or NRG 16-28 is used, the max. admissible temperature limit is 238 °C.

Manufacturer's declaration

For details on the conformity assessment for the individual components refer to the respective installation & operating manuals.

To download or obtain a copy of the current Declaration of Conformity or Manufacturer's Declaration please go to or contact:

GESTRA AG

Münchener Straße 77

28215 Bremen

Germany

Telefon +49 421 3503-0

Telefax +49 421 3503-393

E-Mail info@de.gestra.com

Web www.gestra.de

This declaration is no longer valid if modifications are made to the equipment without consultation with us.



Agencies all over the world: www.gestra.de

GESTRA AG

Münchener Straße 77

28215 Bremen

Germany

Telefon +49 421 3503-0

Telefax +49 421 3503-393

E-Mail info@de.gestra.com

Web www.gestra.de

818941-03/07-2017 kx mm (808828-03) © GESTRA AG Bremen Printed in Germany