

Steam Drier / Steam Purifier

TD

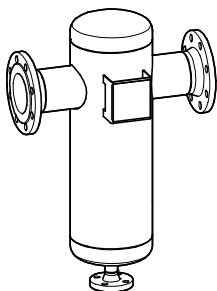

Air Drier / Air Purifier

TP

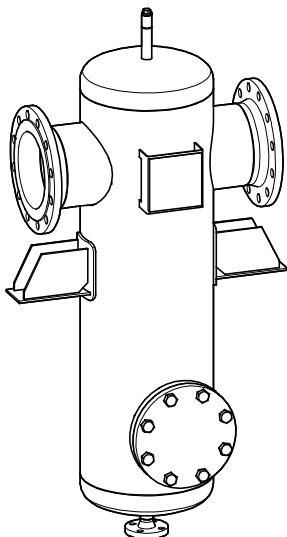

Contents

Foreword	3
Availability.....	3
Formatting features in the document	3
Safety	3
Use for the intended purpose	3
Basic safety notes	4
Qualification of personnel.....	5
Protective gear	5
Typographic features of warning notes.....	5
Formatting features for warnings of property damage	5
Description	5
Scope of supply and equipment specification	5
Task and function.....	7
Storing and transporting the equipment	8
Storing the equipment	8
Transporting the equipment	8
Mounting and connecting the equipment	9
Preparing installation	9
Connecting the equipment	10
Operation	11
After operation	11
Removing external dirt deposits	11
Maintaining the equipment.....	12
Putting the equipment out of operation	12
Removing harmful substances.....	12
Removing the equipment	12
Re-using equipment after storage.....	13
Disposing of the equipment.....	14
Technical data	15
Pressure & temperature ratings.....	15
Dimensions and weights	16
Manufacturer's declaration	18

Foreword

These Installation & Operating Instructions help to ensure the correct, safe and economical use of the TD steam drier/steam purifier or the TP air drier/air purifier. The TD steam drier/steam purifier and TP air drier/air purifier are referred to hereinafter simply as the equipment.

This installation & operating manual is intended for anyone commissioning, using, operating, servicing, cleaning or disposing of this equipment and, in particular, for professional after-sales service technicians, qualified personnel and authorised and trained staff.

All of these persons must read and understand the content of this installation & operating manual.

Following the instructions given in this installation & operating manual helps avoiding danger and increases the reliability and service life of the equipment. Please note that in addition to the instructions given in this installation & operating manual you must also observe all locally applicable rules and regulations concerning the prevention of accidents as well as approved safety guidelines for good professional practice.

Availability

Keep this installation & operating manual together with the plant documentation for future reference. Make sure that this installation & operating manual is available to the operator.

The installation & operating manual is part of the equipment. Please hand over this installation & operating manual when selling the equipment or passing it on.

Formatting features in the document

Certain text elements of this installation & operating manual feature a specific typographic design. You can easily distinguish the following text elements:

Standard text

Cross-reference

- ▶ Listing
 - ▶ Sub-items in listings
- Steps for action.



Here you will find additional useful information and tips serving to assist you in using the equipment to its fullest potential.

Safety

Use for the intended purpose

The TD steam drier/steam purifier is installed in steam and condensate systems.

The equipment is used to separate water, suspended liquids and dirt from steam.

The TP air drier/air purifier is installed in compressed air systems.

The equipment is used to separate water, suspended liquids and dirt from compressed air.

The equipment must only be used within the allowable pressure and temperature limits and only if the chemical and corrosive influences on the equipment are taken into account.

Correct use includes compliance with the instructions given in this installation & operating manual, in particular obedience to all safety instructions.

Note that the equipment is also used incorrectly if the materials of the equipment are not suitable for the fluid.

Basic safety notes

Risk of severe injuries

- ▶ The equipment may become hot during operation. Do not operate the equipment unless thermal insulation or protection against accidental contact prevents you from touching hot surfaces.
- ▶ The equipment is under pressure during operation and may be hot. Before carrying out any work on the equipment make sure that the following requirements are met:
 - ▶ The pipes must be depressurized (0 bar).
 - ▶ The fluid must be completely removed from the pipes and the equipment.
 - ▶ During work on the equipment the installation must be switched off and protected against unauthorised or unintended activation.
 - ▶ The pipes and the equipment must have cooled down to room temperature (approx. 20 °C).
- ▶ If the equipment is used in contaminated areas there is a risk of severe injuries or death caused by harmful substances in or on the equipment. Before working on the equipment make sure that it is completely decontaminated. Always wear the protective clothing prescribed for contaminated areas when working on the equipment.
- ▶ The equipment must only be used with fluids that do not attack the material and the gaskets and sealings of the equipment. Otherwise leaks may occur and hot or toxic fluid could escape.
- ▶ The equipment and its component parts must only be mounted or removed by qualified personnel. A qualified person must be acquainted with and experienced in the following:
 - ▶ Making pipe connections.
 - ▶ Selecting suitable lifting gear and understanding the rules for its safe use.
 - ▶ Working with dangerous (contaminated, hot or pressurized) fluids.

- ▶ If the admissible temperature and pressure limits are exceeded the equipment may be destroyed and hot or pressurized fluid may escape. Make sure that the equipment is only operated within the admissible service range and limits.
For more information on limits and pressure & temperature ratings see name plate and the section "*Technical Data*".
- ▶ If unsuitable lifting gear is used or the gear is used improperly the equipment or parts of it could fall down.
 - ▶ Make sure that only qualified personnel lifts the equipment or parts of it.
 - ▶ Make sure that nobody is standing or working below the hoisted equipment.
 - ▶ Make sure that the lifting gear is of sufficient strength for the load to be hoisted and that the load is properly secured and attached to it. For more information on the nature and weight of the components and safe lifting points please contact the manufacturer.
 - ▶ Make sure that all locally applicable regulations on safety and the prevention of accidents are strictly adhered to.

Risk of minor injuries

- ▶ Sharp edges on internals present the danger of cuts to hands. Always wear industrial gloves when servicing the equipment.
- ▶ If the support of the equipment during installation is insufficient the equipment might fall down, thereby causing bruises or injuries. Make sure the equipment is safely held in place during installation and cannot fall down. Wear protective safety footwear.

Information on property damage or malfunctions

- ▶ Malfunctions will occur if the equipment is installed in a wrong position or with the flow pattern in the opposite direction of the fluid flow. This may result in damage to the equipment or the installation. Make sure that the flow pattern indicated in this installation and operating manual matches the direction of the fluid flow in the pipe.
- ▶ If the material is unsuitable for the fluid, increased wear may occur and fluid may escape. Make sure that the material is suitable for the fluid used in your installation.

Qualification of personnel

A qualified person must be acquainted with and experienced in the following:

- ▶ the pertinent on-site rules and regulations for preventing fire and explosions
- ▶ working on pressure equipment
- ▶ making pipe connections
- ▶ working with dangerous (hot or pressurized) fluids
- ▶ lifting and transporting loads
- ▶ observing all notes and instructions in this installation & operating manual and the applicable documents

Protective gear

The required protective gear depends on the types of fluid used and the regulations on site. For more information on suitable safety clothing and safety gear refer to the safety data sheet of the fluid in question.

Protective gear comprises the following items:

- ▶ protective helmet
- ▶ work boots
- ▶ industrial leather gloves

Typographic features of warning notes



DANGER

Notes with the heading DANGER warn against imminent dangerous situations that can lead to death or serious injuries.



CAUTION

Notes with the heading CAUTION warn against dangerous situations that could lead to minor or moderate injuries.

Formatting features for warnings of property damage

Attention!

This information warns of a situation leading to property damage.

Description

Scope of supply and equipment specification

Scope of supply

Our equipment is delivered packed and ready for assembly.

Equipment specification

The equipment is provided with the following connections:

- ▶ Connection for condensate outlet
- ▶ Connection for condensate inlet
- ▶ Drain connection

Nominal sizes 15 to 175

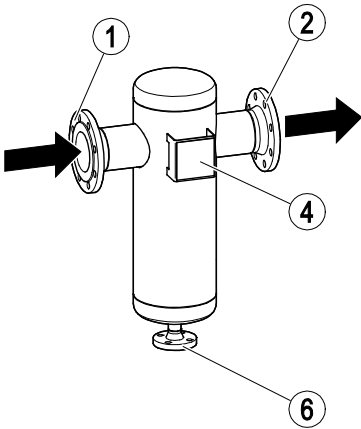

Nominal size 200 upwards

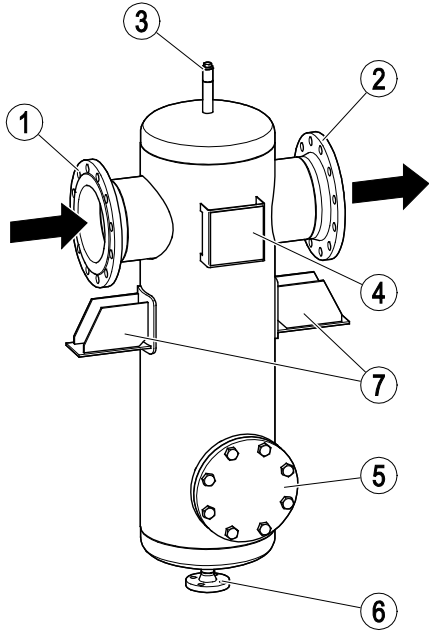

No.	Designation
1	Connection for steam or air inlet
2	Connection for steam or air outlet
4	Name plate
6	Connection for condensate outlet

No.	Designation
1	Connection for steam or air inlet
2	Connection for steam or air outlet
3	Vent (only needed for work by the manufacturer)
4	Name plate
5	Inspection hole (only needed for work by the manufacturer)
6	Connection for condensate outlet
7	Lugs (nominal size 200 upwards)

End connections

The equipment is available with the following end connections:

- ▶ Flanges

Name plate

The following items are indicated on the name plate:

- ▶ Manufacturer
- ▶ Type designation
- ▶ Min. service temperature
- ▶ Max. service temperature
- ▶ Max. service pressure
- ▶ CE marking
- ▶ Year of construction
- ▶ Serial number
- ▶ Type of vessel
- ▶ Approx. weight
- ▶ Body of regulations
- ▶ Test pressure
- ▶ Test date
- ▶ Volume

Pressure Equipment Directive

The equipment must conform to the requirements of the Pressure Equipment Directive (see Manufacturer's Declaration) and can be used for the following media:

- ▶ Fluids of group 2

ATEX

The equipment does not have its own potential ignition source and is not subject to the ATEX Directive (see Manufacturer's Declaration).

Static electricity: Static electricity can be produced in the system if the equipment is installed between pipe flanges.

If the equipment is used in potentially explosive atmospheres, the discharge or prevention of possible electrostatic charging is the responsibility of the manufacturer or operator of the system.

Task and function

Purpose

The TD steam drier/steam purifier is installed in steam and condensate systems.

The equipment is used to separate water, suspended liquids and dirt from steam.

The TP air drier/air purifier is installed in compressed air systems.

The equipment is used to separate water, suspended liquids and dirt from compressed air.

The equipment can function as a steam or air drier and a steam or air purifier, either at the same time or individually.

It separates liquids, entrained water droplets or impurities out of the flow of steam or air, with little loss of pressure.

Function

The humid and impure steam or air flows along the fixed helix (8) in a downward spiral. Above the sump cover plate (9), the flow of the steam or air is reversed, giving rise to centrifugal, impact and swirling forces. These forces separate heavy particles such as impurities or liquids from the steam or air. These heavy particles are then conveyed into the collecting chamber (10).

The change in the direction of flow prevents them from being drawn along by the steam or air.

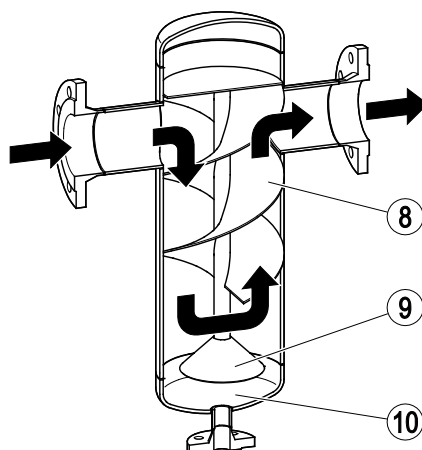

Storing and transporting the equipment

Attention!

Equipment can be damaged if stored or transported improperly.

- Close all openings with the sealing plugs or covers supplied with the equipment or use similar sealing covers.
- Protect the equipment against moisture and corrosive atmospheres.
- Please contact the manufacturer if the specified transport and/or storage requirements cannot be met.

Storing the equipment

- Please observe the following items when storing the equipment:
 - ▶ Do not store the equipment for more than 12 months.
 - ▶ Use the supplied sealing plugs or other suitable seal caps in order to seal off all openings of the equipment.
 - ▶ Protect the sealing surfaces and contact areas against mechanical damage.
 - ▶ Protect the equipment and all components against hard shocks and impacts.
 - ▶ Store the equipment only in closed rooms that meet the following environmental conditions:
 - ▶ Air humidity below 50 %, not condensing
 - ▶ Indoor air: clean, salt-free and non-corrosive
 - ▶ Temperature 5–40 °C.
- Make sure that all these requirements are always met when storing the equipment.
- Please contact the manufacturer if you cannot comply with the recommended storage conditions.

Transporting the equipment



DANGER

Risk of bruises if the equipment or component parts fall down.

- Use suitable lifting gear when moving or lifting the equipment and/or component parts.
- Make sure that the equipment cannot topple over.
- Make sure that nobody is standing below the lifted equipment.

Lightweight equipment may be transported and mounted without using any lifting gear.

To lift equipment the weight of which exceeds approx. 25 kg, you need the help of a second person or suitable lifting gear.

Your physical strength and on-site regulations and conditions determine what weight can be lifted and if support is required.

- Meet the requirements for storage also when transporting the equipment.
- Prior to transport seal off connections with sealing plugs.



If you do not have the sealing plugs supplied with the equipment use appropriate seal caps to seal off the connections.

- For short distances (only a few metres) you can transport the equipment unpacked.
- When transporting the equipment over larger distances use the original packaging.
- If you do not have the original packaging use a box that protects the equipment adequately against corrosion and physical damage.



For a short period of time the equipment may be transported even if the temperature is below 0 °C, provided that the equipment is completely empty and dry.

Mounting and connecting the equipment

Preparing installation



DANGER

Risk of bruises if the equipment or component parts fall down.

- Use suitable lifting gear when moving or lifting the equipment and/or component parts.
- Make sure that the equipment cannot topple over.
- Make sure that nobody is standing below the lifted equipment.

Lightweight equipment may be transported and mounted without using any lifting gear.

To lift equipment the weight of which exceeds approx. 25 kg, you need the help of a second person or suitable lifting gear.

Your physical strength and on-site regulations and conditions determine what weight can be lifted and if support is required.

- Take the equipment out of the transport packaging.
- Check the equipment for transport damage.
- Contact the manufacturer if you detect any kind of shipping damage.

When supplied by the factory, the connections may be sealed off with sealing plugs.

- Remove sealing plugs before mounting the equipment.
- Keep the sealing plugs and the packing for further use.



DANGER

Personnel working on pipes are exposed to safety risks and may suffer severe injuries, poisoning or even loss of life.

- Make sure that no hot or hazardous fluid is in the equipment or the pipes.
- Make sure that the pipes upstream and downstream of the equipment are depressurised.
- Make sure that the installation is switched off and protected against unauthorised or unintended activation.
- Make sure that the equipment and the pipes have cooled down to room temperatures.
- Wear protective clothing that is suitable for the fluid and, if necessary, wear protective gear.

For more information on suitable protective clothing and safety gear refer to the safety data sheet of the fluid in question.

- Drain pipes until they are empty.
- Switch the installation off and protect it against unauthorised or unintended re-activation.

Connecting the equipment



DANGER

Incorrectly connected equipment can cause fatal accidents or severe injuries.

- Make sure that only qualified skilled personnel connect the equipment to pipes.

Specialist personnel must be highly qualified and fully experienced in making pipe connections for the respective type of end connection.

Attention!

The equipment can be damaged if connections are too weak.

- Make sure that the connected equipment is not subjected to any forces or torques.

The operator has to ensure that the equipment and the sealing material is suitable for the fluid used in his system.

- Make sure that all components of the equipment are made of materials that are suitable for the fluid used.
- For more information please contact the manufacturer.
- Make sure that the pipe system of the plant is clean.
- Make sure that the equipment is free from foreign matter.
- Install the equipment in the pipe.
- Fit the equipment such that the connection for the condensate outlet (6) faces down.
- Make sure that the supply of media is connected to the steam or air inlet (1) connection.
- Make sure that the media drain is connected to the steam or air outlet (2) connection.
- Fit a suitable steam trap (11) to the condensate outlet (6) connection.

You can obtain information on suitable steam traps from the manufacturer.

- Make sure that the equipment is not under any stress when installed.

Devices nominal size 200 and upwards are fitted with lugs (7) for support. However, these lugs are not pre-drilled.

- With care, fasten the lugs of devices size 200 and upwards to a support.

The support must be able to bear the full weight of the equipment. You can find information on weight in the technical data on page 15. Instructions for secure fastening can be obtained from the manufacturer.

- Make sure that the equipment is fastened such as to ensure its full weight is supported.

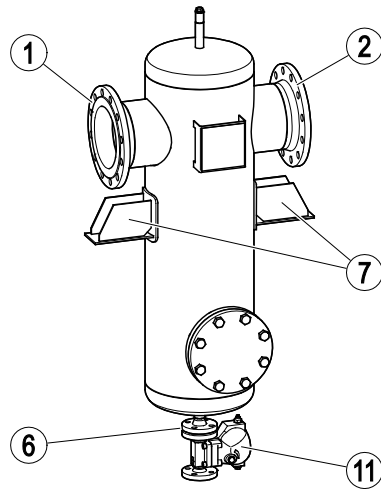

- Make sure that the equipment is safely mounted and that all connections are made correctly.
- When warm, check the flanged unions for tightness.
- Re-tighten the bolted connections if necessary.

During operation the surface of the equipment gets hot. This presents the risk of burns.

- Lag the surface of the equipment with suitable insulating material.

Installation examples

The diagram below shows installation examples without (left) and with (right) stop valves.

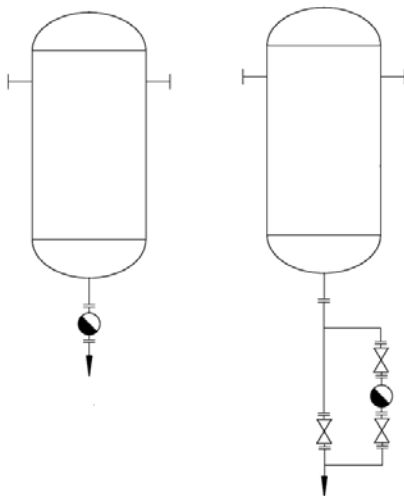

Operation

Do not work on the equipment while it is operating.

After operation



DANGER

If the equipment is used in contaminated areas there is a risk of severe injuries or death caused by harmful substances in or on the equipment.

- Only qualified personnel are allowed to perform work on contaminated equipment.
- Always wear the protective clothing prescribed for contaminated areas when working on the equipment.
- Make sure that the equipment is completely decontaminated before carrying out any service work.
- Follow the pertinent instructions for handling the hazardous substances in question.

Attention!

Frost damage may occur when the installation is shut down.

- Drain the equipment if ambient temperatures below 0 °C (frost) are to be expected.
-
- Drain the equipment using the connected steam trap.

Removing external dirt deposits

- To remove dirt deposits rinse the equipment with fresh water and wipe it with a clean, lint-free cloth.
- To remove any persistent residues use a cleaning agent that is suitable for the material and carefully wipe the equipment with a clean, lint-free cloth.

Maintaining the equipment

The equipment does not require any particular maintenance.

Putting the equipment out of operation

Removing harmful substances



DANGER

If the equipment is used in contaminated areas there is a risk of severe injuries or death caused by harmful substances in or on the equipment.

- Only qualified personnel are allowed to perform work on contaminated equipment.
- Always wear the protective clothing prescribed for contaminated areas when working on the equipment.
- Make sure that the equipment is completely decontaminated before carrying out any service work.
- Follow the pertinent instructions for handling the hazardous substances in question.

Qualified personnel must have extensive experience with and a working knowledge of:

- ▶ pertinent rules and regulations concerning handling hazardous substances
- ▶ special regulations for handling the hazardous substances encountered on site
- ▶ using the required personal protective equipment (PPE) and clothing



Caution

Environmental damage may be caused by poisonous fluid residues.

- Before disposing of the equipment make sure that it is clean and free of fluid residues.
 - For the disposal of all materials observe the pertinent legal regulations concerning waste disposal.
-
- Remove all residues from the equipment.
 - For the disposal of all residues observe the pertinent legal regulations concerning waste disposal.

Removing the equipment



DANGER

Personnel working on pipes are exposed to safety risks and may suffer severe injuries, poisoning or even loss of life.

- Make sure that no hot or hazardous fluid is in the equipment or the pipes.
- Make sure that the pipes upstream and downstream of the equipment are depressurised.
- Make sure that the installation is switched off and protected against unauthorised or unintended activation.
- Make sure that the equipment and the pipes have cooled down to room temperatures.
- Wear protective clothing that is suitable for the fluid and, if necessary, wear protective gear.

For more information on suitable protective clothing and safety gear refer to the safety data sheet of the fluid in question.



DANGER

Risk of bruises if the equipment or component parts fall down.

- Use suitable lifting gear when moving or lifting the equipment and/or component parts.
- Make sure that the equipment cannot topple over.
- Make sure that nobody is standing below the lifted equipment.

-
- Detach the equipment connections from the pipes.
 - Unfasten the lugs from the supports.
 - Place the equipment on a suitable surface.
 - Detach the end connections of the equipment from the pipes.
 - Put the equipment onto a suitable base.
 - Store the equipment as described in section "*Storing the equipment*" on page 8.

Re-using equipment after storage

Observe the following instructions if you want to remove the equipment and use it again somewhere else:

- ▶ Make sure that the equipment is free of any fluid residues.
- ▶ Make sure that all connections are in good condition and leak-free.
- Use the equipment only for its intended purpose and the service conditions for which it was specified.

Disposing of the equipment



Caution

Environmental damage may be caused by poisonous fluid residues.

- Before disposing of the equipment make sure that it is clean and free of fluid residues.
- For the disposal of all materials observe the pertinent legal regulations concerning waste disposal.

The equipment is made of welded sheet steel.

PN	Material		
	Flange	Pipe	Base
16	P250GH	P235GH	P265GH
16	1.4571		
40	P250GH	P235GH	P265GH

Technical data

Pressure & temperature ratings



The values below apply to standard equipment.

The actual pressure and temperature ratings may be reduced by the type of connection used, irrespective of the equipment's nominal ratings.

You can find the values for your equipment on the rating plate.

Flanges	PN	Material	Max. allowable pressure [bar]	Max. allowable temperature [°C]
TD	16	Steel	12	200
TD	40	Steel	28	250
TD	16	Stainless steel	14	200
TP	16	Steel	15	100
TP	40	Steel	34	100
TP	16	Stainless steel	16	100
TP	40	Stainless steel	37	100

Min. admissible temperature: – 10°C

Dimensions and weights



By way of example, the diagram below shows a standard device with flanged end and direction of flow from left to right.

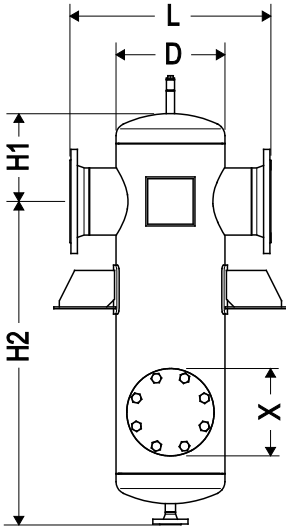

Nominal-size	Nominal inlet/outlet diameter			D	L	H1	H2	Volume	Weight (empty)	
	Steam inlet/outlet	Condensate outlet	Inspection hole X	[mm]				[l]	[kg]	
									PN 16	PN 40
15	15	15	–	60	210	80	310	0.6	4.1	4.1
20	15, 20	15	–	60	220	85	305	0.7	4.8	4.8
25	15, 20, 25	15	–	70	220	95	385	1.4	6.4	6.4
32	20, 25, 32	15	–	70	220	105	375	1.5	7.7	7.7
40	25, 32, 40	15	–	115	270	120	370	3.5	10.5	10.5
50	32, 40, 50	15	–	115	270	130	360	3.7	11.8	11.8
65	40, 50, 65	15	–	170	320	150	460	10.6	21.5	21.5
80	50, 65, 80	15	–	200	360	160	500	14.7	28.3	28.3
100	65, 80, 100	20	–	220	410	190	570	22.9	37.2	37.2
125	80, 100, 125	20	–	250	440	215	655	34.0	48.8	64.0
150	100, 125, 150	25	–	270	500	230	740	49.0	62.0	87.0
175	125, 150	25	–	320	560	240	870	76.0	83.0	113.0
200	150, 200	25	150	350	650	285	1,055	119.0	151.0	216.0
250	150, 200, 250	25	150	400	720	330	1,170	178.0	201.0	316.0

Manufacturer's declaration

For more information on the Conformity Assessment according to European rules refer to our Declaration of Conformity or our Declaration by Manufacturer.

To download the current Declaration of Conformity or Declaration by Manufacturer go to www.gestra.en/documents or contact:

GESTRA AG

Münchener Straße 77

28215 Bremen

Germany

Telefon +49 421 3503-0

Telefax +49 421 3503-393

E-Mail info@de.gestra.com

Web www.gestra.de

This declaration is no longer valid if modifications are made to the equipment without consultation with us.



Agencies all over the world: www.gestra.de

GESTRA AG

Münchener Strasse 77

28215 Bremen

Germany

Phone +49 421 3503-0

Fax +49 421 3503-393

e-mail info@de.gestra.com

Web www.gestra.com

819479-01/09-2017 kx_mm (808935-02) © GESTRA AG Bremen Printed in Germany