



FLOWSERVE



GESTRA

GESTRA Steam Systems

SMK 22
SMK 22-51
SMK 22-81
SMK 22-82

EN
English

Installation Instructions 810481-05

Steam Traps

SMK 22, SMK 22-51, SMK 22-81, SMK 22-82

Contents

Page

Title

Title page	1
------------------	---

Inhalt

Contents	2, 3
----------------	------

Important Notes

Usage for the intended purpose	4
Safety note	4
Danger	4
Attention	4
Application of European Directives	4

Explanatory Notes

Scope of supply	5
-----------------------	---

Technical Data

Name plate / marking	6
----------------------------	---

Design

Component parts SMK 22	7
Component parts SMK 22-51	8
Component parts SMK 22-81, SMK 22-82	9
Key	10

Installation

SMK 22, SMK 22-51, SMK 22-81, SMK 22-82	11
Installation instructions	11
Attention	11
Heat treatment of welds	11

Commissioning Procedure

Danger	12
--------------	----

Contents - continued -

Page

Operation

SMK 22, SMK 22-51, SMK 22-81, SMK 22-82	12
Thermostatic capsule	12
Thermostatic capsule SMK 22-82 STERILINE 2	

Maintenance

Danger	13
Cleaning / replacing thermostatic capsule	13
Tools	13
Tightening torques	13

Spare Parts

SMK 22, SMK 22-51, SMK 22-81, SMK 22-82	14
Spare parts list	14

Decommissioning

Danger	15
Attention	15
Disposal	15
Manufacturer's Declaration	15

Back

GESTRA Agencies	16
-----------------------	----

Important Notes

Usage for the intended purpose

Use the steam trap only for the discharge of condensed water from steam lines or for air venting from steam spaces. Use this equipment only within the specified pressure and temperature ratings and check the corrosion resistance and chemical suitability for the application in question.

Do not expose the control membrane to superheat conditions above 5 degrees C.

Safety note

Installation, commissioning, maintenance and retrofitting of this equipment must only be performed by adequately trained persons who have a recognized level of competence.



Danger

The equipment is under pressure and hot during operation. Risk of severe burns and injuries to the whole body.

Installation and maintenance work should only be carried out when the system is depressurized (0 bar) and cold (20 °C).

The equipment must be isolated and vented from both upstream and downstream pressure before installation or maintenance work is performed.

Sharp edges on internals present a danger of cuts to hands.

Always wear industrial gloves when servicing the equipment.



Attention

The name plate / marking specifies the technical features of the equipment.

Do not commission or operate any item of equipment that does not bear its specific name plate. The pressure and temperature ratings on the name plate of the equipment must meet the requirements of the installation.

Application of European Directives

Pressure Equipment Directive

The equipment conforms to this directive (see „Manufacturer’s Declaration“ section) and can be used for the following media:

- Fluids of group 2

ATEX Directive

The equipment does not have its own potential ignition source and is not subject to this directive (see „Manufacturer’s Declaration“ section).

When installed, static electricity may arise between the equipment and the connected system. When used in potentially explosive atmospheres, the plant manufacturer or plant operator is responsible for discharging or preventing possible static charge.

If it is possible for medium to escape, e.g. through actuating mechanisms or leaks in threaded joints, the plant manufacturer or plant operator must take this into consideration when dividing the area into zones.

Explanatory Notes

Scope of supply

SMK 22

1 Steam trap SMK 22
1 Installation manual

SMK 22-51

1 Steam trap SMK 22-51
1 Installation manual

SMK 22-81

1 Steam trap SMK 22-81
1 Installation manual

SMK 22-82

1 Steam trap SMK 22-82
1 Installation manual

Technical Data

Name plate / marking

The temperature/pressure ratings are indicated on the trap body or on the name plate. For more information see GESTRA technical documents such as data sheets and the Technical Information.

The specification on the body indicates the type and design:

- Name/logo of the manufacturer
- Type designation
- Pressure class PN or Class
- Material number
- Max. temperature
- Max. pressure
- Direction of flow
- Quarter and year of production



Fig. 1



Fig. 2



Fig. 3



Fig. 4



Fig. 5

Design

Component parts SMK 22

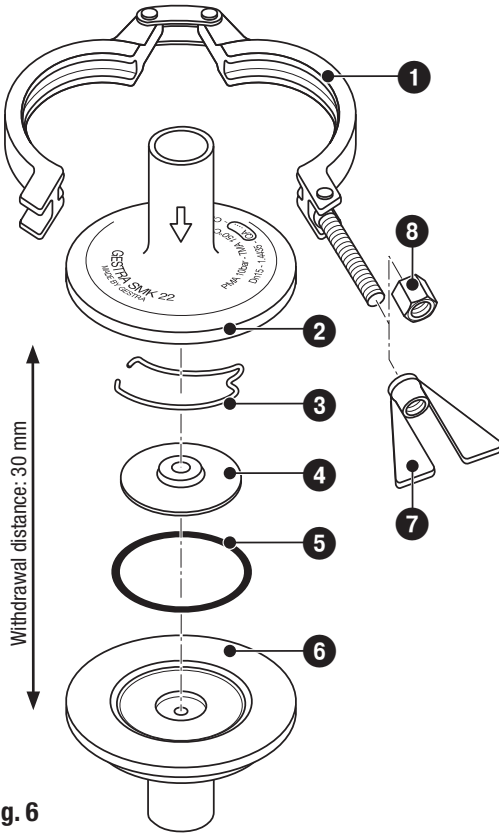

Fig. 6

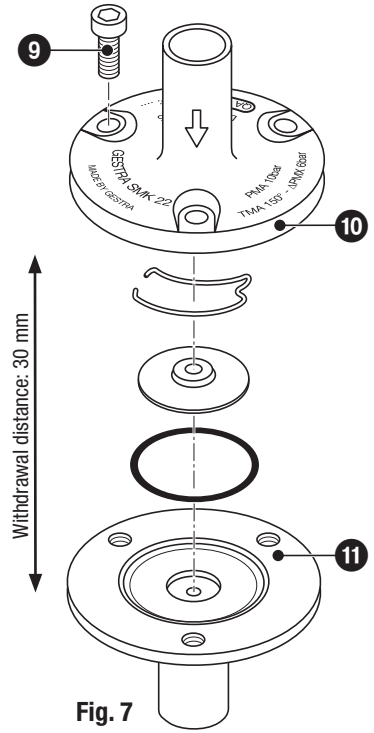

Fig. 7

Component parts SMK 22-51

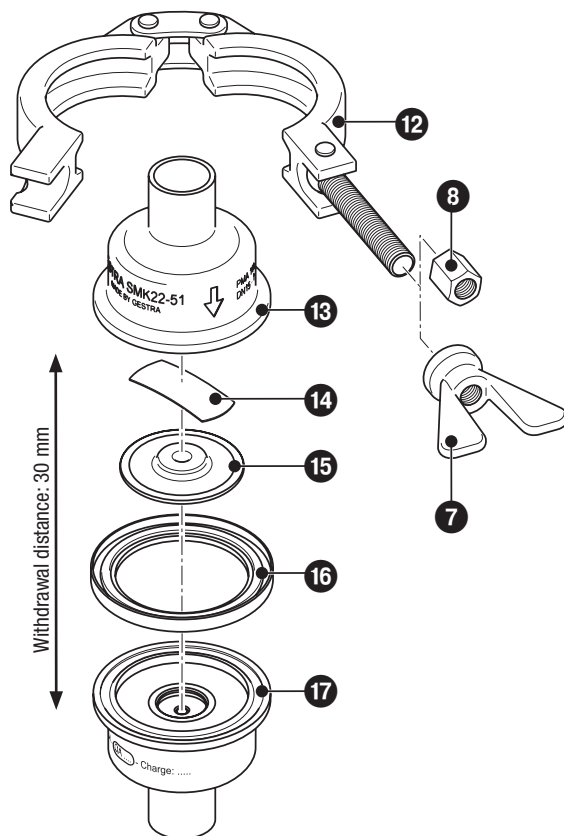

Fig. 8

Component parts SMK 22-81, SMK 22-82

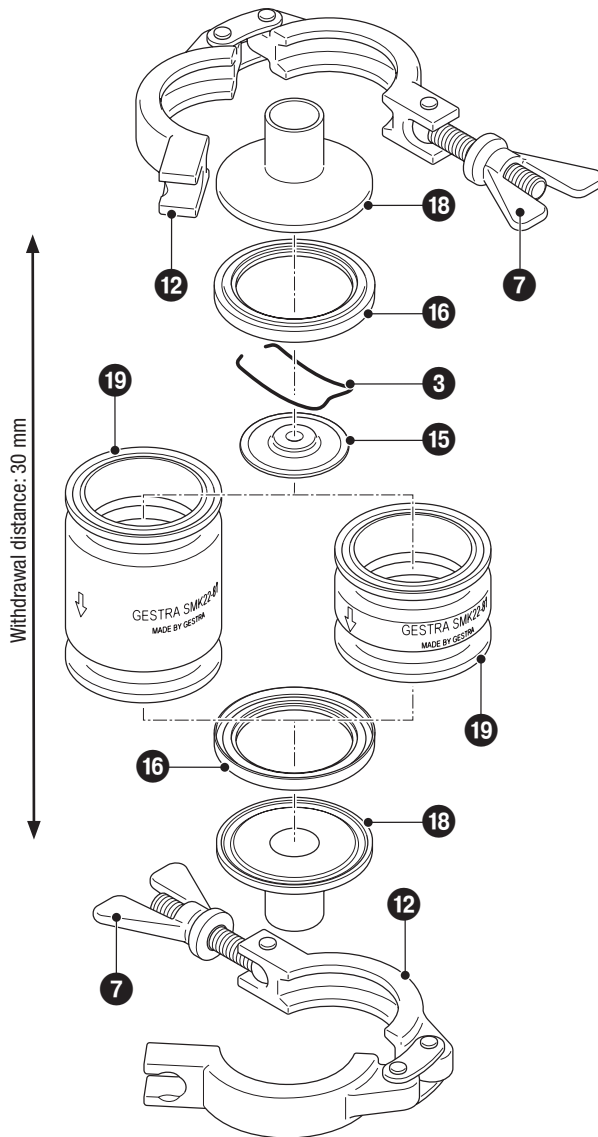

Fig. 9

Component Parts - continued -

Key

- 1 Joint clamp SMK 22
- 2 Upper body part SMK 22
- 3 Spring SMK 22, SMK 22-81, SMK 22-82
- 4 Thermostatic capsule SMK 22
- 5 Body gasket of EPDM (PTFE) SMK 22
- 6 Lower body part SMK 22
- 7 Wing nut
- 8 Hexagon nut (optional)
- 9 Socket-head cap screw M6 x 12 SMK 22
- 10 Upper body part SMK 22
- 11 Lower body part SMK 22
- 12 Joint clamp SMK 22-51, SMK 22-81, SMK 22-82
- 13 Upper body part SMK 22-51
- 14 Spring SMK 22-51
- 15 Thermostatic capsule SMK 22-51, SMK 22-81, SMK 22-82
- 16 Body gasket PTFE SMK 22-51, SMK 22-81, SMK 22-82
- 11 Lower body part SMK 22
- 18 Clamp support SMK 22-81, SMK 22-82
- 19 Functional unit SMK 22-81, SMK 22-82

Installation

SMK 22, SMK 22-51, SMK 22-81, SMK 22-82

The SMK 22... can be installed in any position. Make sure that the flow arrow on the trap body matches the direction of flow of the steam. When mounted in a vertical line with downward flow the trap is self-draining.

Installation instructions

1. Make sure that the flow arrow on the trap body matches the direction of flow of the steam.
 2. Consider space required for servicing the trap. When the trap is installed a minimum withdrawal space for servicing is required for removing trap parts (see **Design, Component Parts SMK 22...**).
 3. Remove plastic plugs. They are only used as transit protection.
 4. Clean end connections.
- 5.1 Install steam trap with releasable end connections (e. g. clamp).
- 5.2 For butt-weld ends: Apply welding process 141 according to ISO 4063 (or equivalent standard).
Remove the body gaskets **5** and **16** before welding the steam trap in place.



Attention

- Only qualified welders certified according to DIN EN 287 (or equivalent national standards) may weld steam traps into pipelines.

Heat treatment of welds

A subsequent heat treatment of the welds is not required.

Commissioning Procedure

Make sure that all connections have been adequately pressure tested according to local requirements.



Danger

The equipment is under pressure and hot during operation. Risk of severe burns and injuries to the whole body.

Installation and maintenance work should only be carried out when the system is depressurized (0 bar) and cold (20 °C).

The equipment must be isolated and vented from both upstream and downstream pressure before installation or maintenance work is performed.

Sharp edges on internals present a danger of cuts to hands.

Always wear industrial gloves when servicing the equipment.

Operation

SMK 22, SMK 22-51, SMK 22-81, SMK 22-82

SMK 22, SMK 22-51, SMK 22-81 and SMK 22-82 can be serviced (see **Maintenance**).

Thermostatic capsule

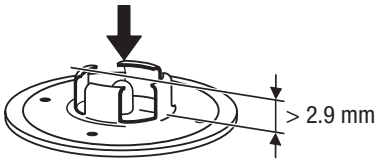

Fig. 10
Capsule intact

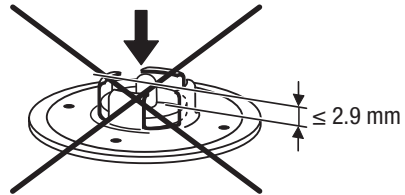

Fig. 11
Capsule defective, must be replaced

Thermostatic capsule SMK 22-82 STERILINE 2

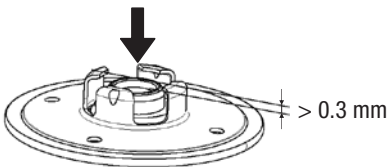

Fig. 12
Capsule intact

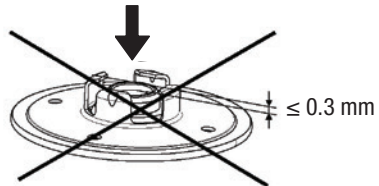

Fig. 13
Capsule defective, must be replaced

Maintenance

GESTRA steam traps SMK 22, SMK 22-51, SMK 22-81, SMK 22-81 do not require any special maintenance. However, if used in new installations which have not been rinsed check and clean the thermostatic capsule after the commissioning procedure.



Danger

The equipment is under pressure and hot during operation. Risk of severe burns and injuries to the whole body.

Installation and maintenance work should only be carried out when the system is depressurized (0 bar) and cold (20 °C).

The equipment must be isolated and vented from both upstream and downstream pressure before installation or maintenance work is performed.

Sharp edges on internals present a danger of cuts to hands.

Always wear industrial gloves when servicing the equipment.

Cleaning / replacing / removing thermostatic capsule

1. Unscrew hexagon nut **8** or wing nut **7** of joint clamp **1** / **12** and remove joint clamp. **Fig. 6, Fig. 8, Fig. 9**
2. Unscrew socket-head cap screws **9**. **Fig. 7**
3. Remove and clean thermostatic capsule.
4. Replace thermostatic capsule in case of signs of wear or damage.
5. Clean body and internals. Clean all gasket surfaces.
6. Press thermostatic capsule onto the lower body part.
7. Insert new body gasket **5** / **16**.
8. Assemble upper and lower body part.
9. Fit joint clamp and tighten wing nut / hexagon nut with the torque indicated in the table **Tightening Torques**.
10. Screw in socket-head cap screw **9** and tighten with the torque indicated in the table **Tightening Torques**.

Tools

- Combination spanner A. F. 15 mm, DIN 3113, form B
- Key for hexagon socket screws with pilot A. F. 6 mm, DIN 6912
- Torque spanner 5 - 22.5 Nm, DIN ISO 6789

Tightening torques

Item	Designation	Torque for tightening [Nm]
8	Hexagon nut	8
7	Wing nut	8
9	Socket-head cap screw M6 x 12	7

All torques indicated in the table are based at a room temperature of 20 °C.

Spare Parts

SMK 22, SMK 22-51, SMK 22-81, SMK 22-82

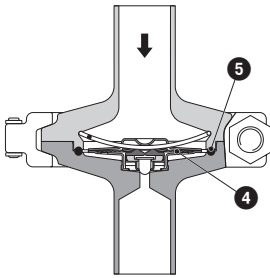

Fig. 14 SMK 22

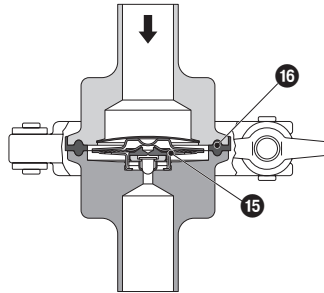

Fig. 15 SMK 22-51

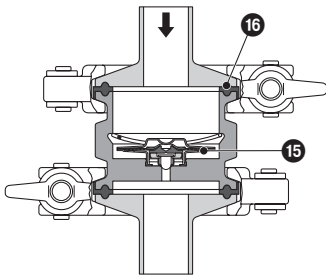

Fig. 16 SMK 22-81, SMK 22-82

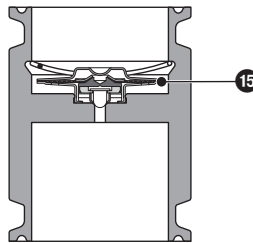

Fig. 17 Functional unit

Spare parts list

Item	Designation		Stock code
4 5	Thermostatic capsule 5H1 Steriline, O ring EPDM, FDA compliant, SMK 22	Up to year of construction 2012	450030
		Up to year of construction 2013	450032
4 5	Thermostatic capsule 5H1 Steriline, O ring PTFE, FDA compliant, SMK 22	Up to year of construction 2012	450031
		Up to year of construction 2013	450033
15 16	Thermostatic capsule 5H1 Steriline 1, body gasket PTFE, FDA compliant, SMK22-51		450034
15 16	Thermostatic capsule 5H1 Steriline 1, body gasket PTFE, FDA compliant, SMK22-81		450035
15 16	Thermostatic capsule 0H3 Steriline 2, body gasket PTFE, FDA compliant, SMK22-82		450036
15	5 Thermostatic capsules 5H1 Steriline 1, for functional unit SMK22-81		450027
15	5 Thermostatic capsules 0H3 Steriline 2, for functional unit SMK22-82		450029

Decommissioning



Danger

The equipment is under pressure and hot during operation. Risk of severe burns and injuries to the whole body.

Installation and maintenance work should only be carried out when the system is depressurized (0 bar) and cold (20 °C).

The equipment must be isolated and vented from both upstream and downstream pressure before installation or maintenance work is performed.

Sharp edges on internals present a danger of cuts to hands.

Always wear industrial gloves when servicing the equipment.



Attention

Drain steam trap if the installation is shut down and ambient temperatures ≤ 0 °C (frost) are to be expected.

Disposal

For the disposal of the equipment observe the pertinent legal regulations concerning waste disposal.

Manufacturer's Declaration

For more information on the Conformity Assessment according to European rules refer to our Declaration of Conformity or our Declaration by Manufacturer.

To receive the current Declaration of Conformity or Declaration by Manufacturer please contact:

Manufacturer: GESTRA AG

P. O. Box 10 54 60, D-28054 Bremen

Telephone: +49 (0) 421 35 03 0

Fax: +49 (0) 421 35 03 393

E mail: gestra.ag@flowserve.com

Internet: www.gestra.com

This declaration is no longer valid if modifications are made to the equipment without consultation with us.



GESTRA

Agencies all over the world:

www.gestra.de

UK and ROI

Flowserve GB Limited (GESTRA Division)

Unit 1 Sopwith Park

Royce Close

West Portway Business Park

Andover, Hampshire SP10 3TS

Tel. 0044 16 35 / 46 99 9

Fax 0044 16 35 / 3 60 34

E-Mail gestraSalesUK@flowserve.com

Web www.flowserve.com

South Africa

Flowserve SA (Pty) Ltd.

Unit No. 1

Director Road

Spartan Extension 2

Kempton Park 1613

Tel. 0027 11 / 9 23 73 00

Fax 0027 11 / 9 74 64 20

E-Mail tvniekerk@flowserve.com

Web www.flowserve.com

Singapore

Flowserve Pte. Ltd.

12 Tuas Avenue 20

Singapore 638824

Tel. 0065 / 68 79 89 00

Fax 0065 / 68 62 49 40

Web www.flowserve.com

USA

Flowserve Corporation GESTRA Division

4001 Flowserve Way, Suite 300

Pasadena, TX 77503-2651

Tel. 001 713 / 286-3100

Fax 001 281 / 479-0081

E-Mail fcd-gestra-usa@flowserve.com

Web www.flowserve.com

GESTRA AG

P. O. Box 10 54 60, D-28054 Bremen

Münchener Str. 77, D-28215 Bremen

Tel. 0049 (0) 421 35 03 - 0

Fax 0049 (0) 421 35 03 - 393

E-Mail gestra.ag@flowserve.com

Web www.gestra.de

