

GESTRA Steam Systems

Product Range A1

Steam Traps

MK 45-1, MK 45-2, MK 45A-1, MK 45A-2

PN 40

DN 15, 20, 25 (½", ¾", 1")

MK 45

Description

Thermostatic steam trap with corrosion-resistant thermostatic capsule. With Y-type strainer and integrated non-return action.

Do not expose the control membrane to superheat conditions above 5 °C.

Steam traps with standard capsule "N" discharge condensate with approx. 10 K below boiling temperature, traps with capsule "U" with an undercooling of approx. 30 K and traps with capsule "H" with approx. 5 K undercooling.

MK 45-1, MK 45A-1 with tandem seat (double sealing)

Particularly for low condensate flowrates. Optionally with standard capsule 5N1 or special capsule 5U1 or 5H1.

MK 45-2, MK 45A-2 with single seat

For larger condensate flowrates. Optionally with standard capsule 5N2 or special capsule 5U2 or 5H2.

Pressure /Temperature Ratings & End Connections

MK 45, flanged PN 40, EN 1092-1							
PMA (max. allowable pressure)	[barg]	40.0	33.3	27.6	25.7	23.8	13.1
TMA (max. allowable temperature)	[°C]	20	200	300	350	400	450
Δ PMX (admissible differential pressure)	[barg]	32					

Based on EN 1092-1 (2007)

MK 45, flanged Class 150, ASME B16.5							
PMA (max. allowable pressure)	[barg]	19.6	13.8	10.2	8.4	6.5	5.5
TMA (max. allowable temperature)	[°C]	-29/38	200	300	350	400	425
PMA (max. allowable pressure)	[psig]	285	200	140	125	95	80
TMA (max. allowable temperature)	[°F]	-20/100	400	600	650	750	800
Δ PMX (admissible differential pressure)	[barg]	32					

Based on ASME B16.5, ASME B16.34

MK 45, flanged Class 300, ASME B16.5, butt-weld ends EN 12627 socket-weld ends EN 12760, socket-weld ends Class 3000, ASME B16.11 screwed sockets BSP, ISO 228-1, screwed sockets NPT, ASME B16.11							
PMA (max. allowable pressure)	[barg]	51.1	43.8	39.8	37.6	34.7	28.8
TMA (max. allowable temperature)	[°C]	-29/38	200	300	350	400	425
PMA (max. allowable pressure)	[psig]	740	635	570	550	505	410
TMA (max. allowable temperature)	[°F]	-20/100	400	600	650	750	800
Δ PMX (admissible differential pressure)	[barg]	32					

Based on ASME B16.5, ASME B16.34

MK 45A, flanged PN 40, EN 1092-1							
PMA (max. allowable pressure)	[barg]	40.0	31.8	29.9	27.6	26.4	25.7
TMA (max. allowable temperature)	[°C]	20	200	250	300	350	400
Δ PMX (admissible differential pressure)	[barg]	32					

Based on EN 1092-1 (2007)

MK 45A, flanged Class 150, ASME B16.5							
PMA (max. allowable pressure)	[barg]	15.9	11.2	10.0	8.4	6.5	4.6
TMA (max. allowable temperature)	[°C]	-29/38	200	300	350	400	450
PMA (max. allowable pressure)	[psig]	230	160	140	125	95	65
TMA (max. allowable temperature)	[°F]	-20/100	400	600	650	750	850
Δ PMX (admissible differential pressure)	[barg]	32					

Based on ASME B16.5, ASME B16.34

MK 45A, flanged Class 300, ASME B16.5, butt-weld ends EN 12627 socket-weld ends EN 12760, socket-weld ends Class 3000, ASME B16.11 screwed sockets BSP, ISO 228-1, screwed sockets NPT, ASME B16.11							
PMA (max. allowable pressure)	[barg]	41.4	29.2	26.1	25.1	24.3	23.4
TMA (max. allowable temperature)	[°C]	-29/38	200	300	350	400	450
PMA (max. allowable pressure)	[psig]	600	420	370	365	355	340
TMA (max. allowable temperature)	[°F]	-20/100	400	600	650	750	850
Δ PMX (admissible differential pressure)	[barg]	32					

Based on ASME B16.5, ASME B16.34

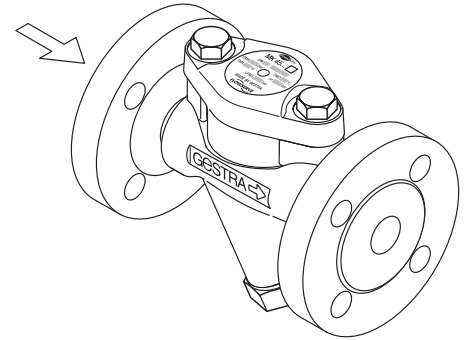

MK 45 with flanges

Materials

Type	MK 45	
Designation	DIN / EN	ASME
Body and cover	1.0460	A105
Hexagon-head cap screws	1.7225	A193 B7
Gasket	Graphite/CrNi	
Regulating membrane (capsule)	Hastelloy®	
Other internals	Stainless steels	

Type	MK 45A	
Designation	DIN / EN	ASME
Body and cover	1.4404	F316L
Hexagon-head cap screws	A2-70	A193 B8
Gasket	Graphite/CrNi	
Regulating membrane (capsule)	Hastelloy®	
Other internals	Stainless steels	

Component Parts MK 45, MK 45A

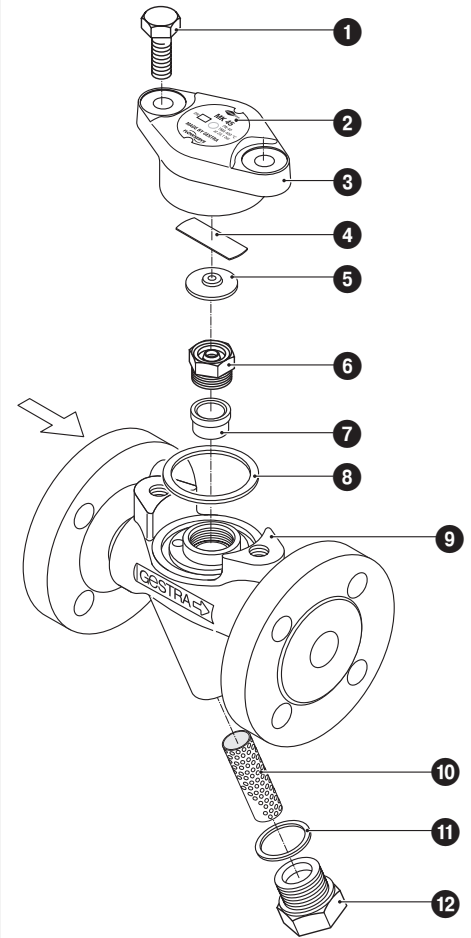

Key

- ① Hexagon-head screw M 10 x 25
- ② Name plate
- ③ Cover
- ④ Spring
- ⑤ Regulating membrane (capsule)
- ⑥ Nozzle insert with non-return cone
- ⑦ Bushing (interference fitted, no spare part)
- ⑧ Gasket 40 x 48 x 2
- ⑨ Body
- ⑩ Strainer
- ⑪ Gasket A 24 x 29
- ⑫ Sealing plug

Spare parts list see page 3

Dimensions

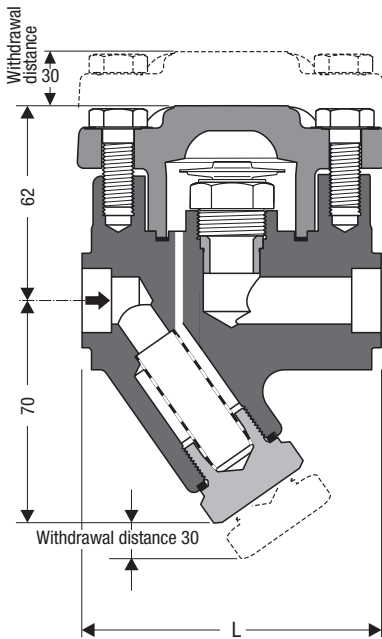
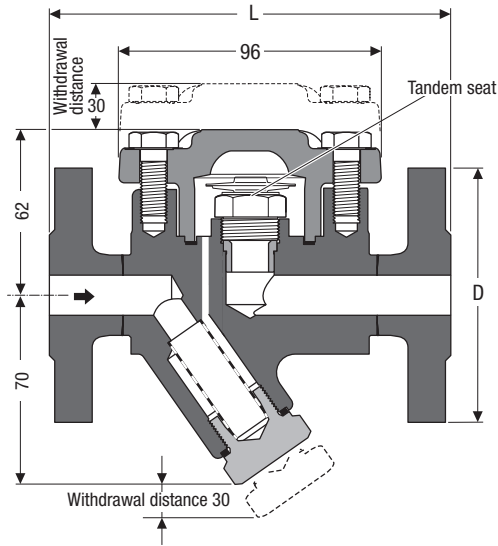

Weights and dimensions for traps with flanged ends

Type	Flanged to	EN 1092-1 PN 40			ASME B 16.5 Class 150			ASME B 16.5 Class 300		
		15	20	25	15	20	25	15	20	25
MK 45, MK 45A	DN	1/2"	3/4"	1"	1/2"	3/4"	1"	1/2"	3/4"	1"
	D [mm]	95	105	115	88.9	98.4	107.9	95.2	117.5	123.8
	L [mm]	150	150	160	150	150	160	150	150	160
	[kg]	3.7	4.3	4.8	3.7	4.3	4.8	3.7	4.3	4.8

Weights and dimensions for traps with butt-weld ends

Type	Butt-weld ends to	EN 12627 Edge form to ISO 9692, code number 1.3			ASME B 16.25 ASME B 36.10		
		15	20	25	15	20	25
MK 45, MK 45A	DN	1/2"	3/4"	1"	1/2"	3/4"	1"
	for pipe	21.3 x 2.0	26.9 x 2.3	33.7 x 2.6	21.3 x 2.8	26.7 x 2.9	33.4 x 3.4
	L [mm]	200	200	200	200	200	200
	[kg]	2.5	2.5	2.5	2.5	2.5	2.5

Butt-weld ends for other pipe sizes available on request.

Weights and dimensions for traps with socket-weld ends

Type	Socket-weld ends to	DIN EN 12760, ASME B 16.11 Class 3000		
		15	20	25
MK 45, MK 45A	DN	1/2"	3/4"	1"
	L [mm]	95	95	95
	[kg]	2.2	2.1	2.0

Weights and dimensions for traps with screwed sockets

Type	Screwed sockets to	BSP: ISO 228-1, NPT: ASME B 16.11		
		15	20	25
MK 45, MK 45A	DN	1/2"	3/4"	1"
	L [mm]	95	95	95
	[kg]	2.2	2.1	2.0

Spare Parts

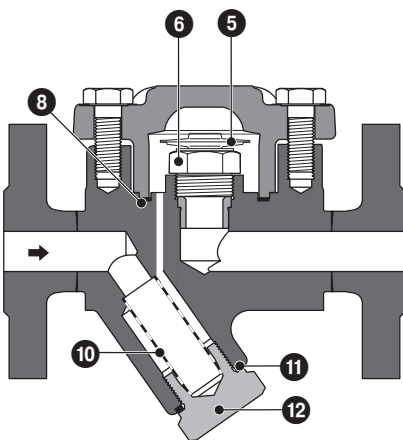

Item	Designation	Stock code	
		MK 45-1	MK 45-2
5 6 8	Membrane regulator, complete, 5N1	375 109	
	Membrane regulator, complete, 5U1	375 111	
	Membrane regulator, complete, 5H1	378 521	
5 6 8	Membrane regulator, complete, 5N2		375 110
	Membrane regulator, complete, 5U2		375 112
	Membrane regulator, complete, 5H2		377 589
10 11 12	Strainer set, cpl.	375 113	375 113
		375 382	375 382
5	Thermostatic capsule ¹⁾ 5N1	376 165	
	Thermostatic capsule ¹⁾ 5U1	376 166	
	Thermostatic capsule ¹⁾ 5H1	376 173	
5	Thermostatic capsule ¹⁾ 5N2		376 167
	Thermostatic capsule ¹⁾ 5U2		376 168
	Thermostatic capsule ¹⁾ 5H2		376 174
8	Cover gasket ²⁾ 40 x 48 x 2, graphite	375 159	375 159
11	Plug gasket ²⁾ A 24 x 29, stainless steel	375 162	375 162

¹⁾ Packaged 10 per box. For smaller quantities please contact your local dealer.

²⁾ Minimum purchasing quantity 50 pcs. For smaller quantities please contact your local dealer.

Steam Traps

**MK 45-1, MK 45-2,
MK 45A-1, MK 45A-2
PN 40
DN 15, 20, 25 (½", ¾", 1")**

Capacity Charts

The charts show the maximum capacities for hot and cold condensate.

Curve 1

Indicates the max. capacity of hot condensate that steam traps with 5N.. capsule can discharge with approx. 10 K below boiling temperature and traps with 5U... capsule can discharge with approx. 30 K below boiling temperature..

Curve 2

Discharge capacity for cold condensate at 20 °C.

Specification Text

GESTRA Steam trap, DN 15 / DN 20 / DN 25

Type: MK 45-1 / MK 45-2 (carbon steel)

Type: MK 45A-1 / MK 45A-2 (high-alloy stainless steel)

End connection: Flanged / socket-weld ends / butt-weld ends / screwed sockets

MK 45-1, MK 45-2 with tandem seat and self-centering cone

Nominal size: DN 15/DN 20/DN 25 / ½"/¾"/1"

Pressure rating: PN 40 / CL 150 / CL 300

Thermostatic capsule: **N** = Standard, Δt approx. 10 K

U = Undercooling, Δt approx. 30 K

H = Undercooling, Δt approx. 5 K

Approvals

GOST-R

Inspection & Certification

Documentation regarding material tests and in-house examination with test report EN10204-2.2 or inspection certificate EN10204-3.1 available at extra cost. All inspection requirements have to be stated with the enquiry or order. After supply of the equipment certification cannot be established. Charges and extent of the above mentioned test certificates as well as the different tests confirmed therein are listed in our Price List "Test and Inspection Charges for Standard Equipment". For other tests and inspections than those listed above, please consult us.

PED (Pressure Equipment Directive)

The equipment fulfills the requirements of the Pressure Equipment Directive PED 97/23/EC. For use with fluids of group 2.

The equipment is excluded from the scope of the PED according to section 3.3 and must not bear a CE marking.

ATEX (Atmosphère Explosible)

The equipment does not have its own potential source of ignition and is therefore not subject to the ATEX Directive 94/9/EC. Applicable in Ex zones 0, 1, 2, 20, 21, 22 (1999/92/EC). The equipment is not Ex marked.

Supply in accordance with our general terms of business.

Capacity Chart for MK 45-1, MK 45A-1

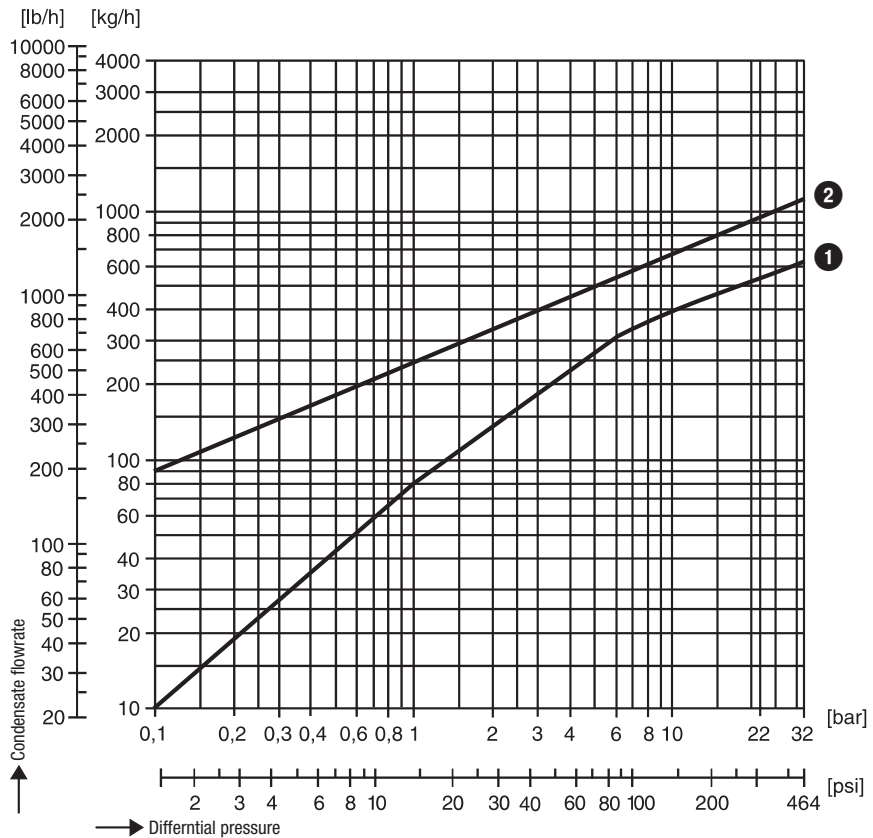

Capacity Chart for MK 45-2, MK 45A-2

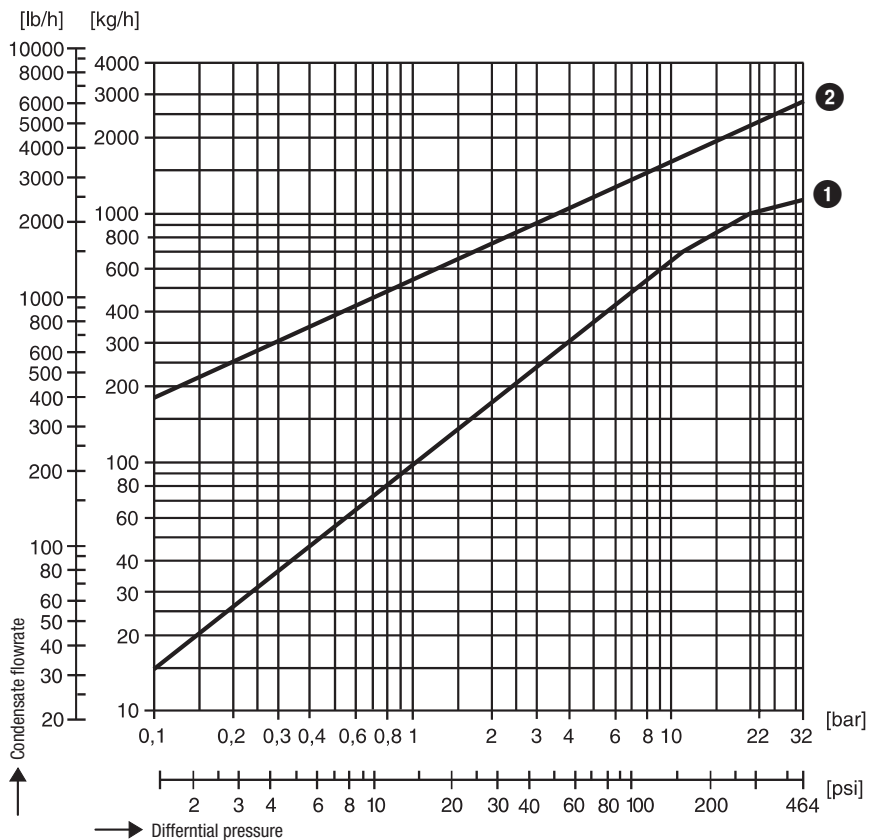

GESTRA AG

P. O. Box 10 54 60, D-28054 Bremen

Münchener Str. 77, D-28215 Bremen

Telephone 0049 (0) 421 35 03 - 0, Fax 0049 (0) 421 35 03-393

E-mail gestra.gmbh@flowserve.com, Internet www.gestra.de



GESTRA